

# Where Sun Meets Water

## FLOATING SOLAR MARKET REPORT

Public Disclosure Authorized

Public Disclosure Authorized

Public Disclosure Authorized

Public Disclosure Authorized

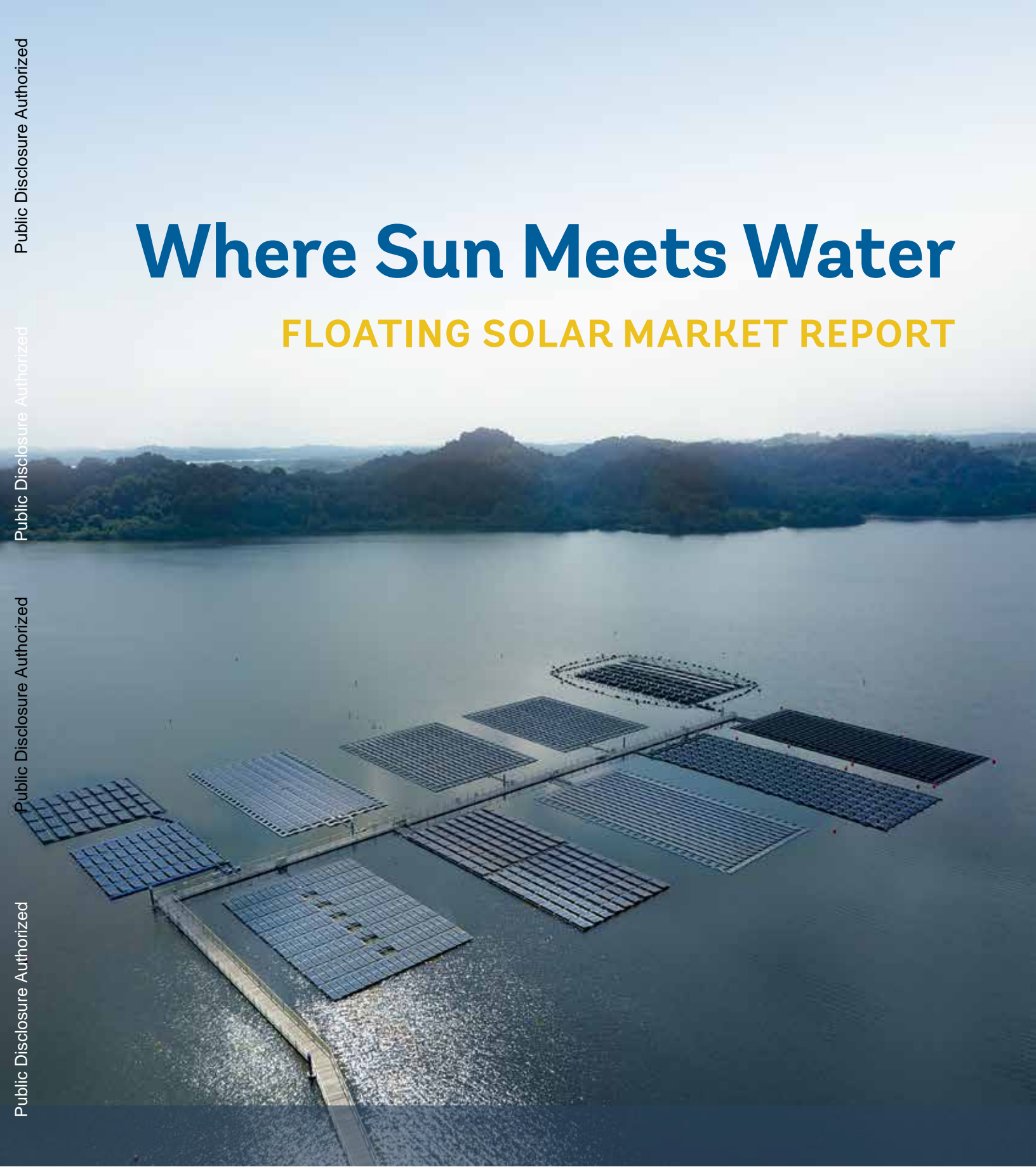

This report was researched and prepared by the Solar Energy Research Institute of Singapore (SERIS) at the National University of Singapore (NUS), under contract from the World Bank, with inputs and editing from staff and consultants at the World Bank and the International Finance Corporation (IFC). Authors and contributors to the report were, from SERIS: Thomas Reindl, Celine Paton, Abhishek Kumar, Haohui Liu, Vijay Anand Krishnamurthy, Ji Zhang, Stephen Tay, Yanqin Zhan; from the World Bank: Zuzana Dobrotkova, Sandra Chavez, Chris Jackson, Oliver Knight, Sabine Corniet, Pierre Audinet, Gailius Draugelis, Surbhi Goyal, Pierre Lorillou; and from IFC: Stratos Tavoulaareas, Dzenan Malovic, Hemant Mandal, Jean-Francois Mercier, Ishan Purohit. The work was funded by the Energy Sector Management Assistance Program (ESMAP), The Government of the Kingdom of Denmark as represented by the Ministry of Foreign Affairs, and the World Bank, and also benefited from in-kind contributions from SERIS.

© 2019 International Bank for Reconstruction and Development / The World Bank  
1818 H Street NW | Washington DC 20433 | USA  
202-473-1000 | [www.worldbank.org](http://www.worldbank.org)

This work is a product of the staff of the World Bank with external contributions. The findings, interpretations, and conclusions expressed in this work do not necessarily reflect the views of the World Bank, its Board of Executive Directors, or the governments they represent. The World Bank does not guarantee the accuracy of the data included in this work. The boundaries, colors, denominations, and other information shown on any map in this work do not imply any judgment on the part of the World Bank concerning the legal status of any territory or the endorsement or acceptance of such boundaries.

#### **RIGHTS AND PERMISSIONS**

The material in this work is subject to copyright. Because the World Bank encourages dissemination of its knowledge, this work may be reproduced, in whole or in part, for noncommercial purposes as long as full attribution to this work is given.

Any queries on rights and licenses, including subsidiary rights, should be addressed to World Bank Publications, World Bank Group, 1818 H Street NW, Washington, DC 20433, USA; fax: 202-522-2625; [pubrights@worldbank.org](mailto:pubrights@worldbank.org). ESMAP would appreciate a copy of or link to the publication that uses this publication for its source, addressed to ESMAP Manager, World Bank, 1818 H Street NW, Washington, DC, 20433 USA; [esmap@worldbank.org](mailto:esmap@worldbank.org).

All images remain the sole property of their source and may not be used for any purpose without written permission from the source.

Attribution—Please cite the work as follows:

World Bank Group, ESMAP and SERIS. 2019. Where Sun Meets Water: Floating Solar Market Report. Washington, DC: World Bank.

Front Cover: © SERIS

Back Cover: © Pixbee/EDP S.A.

# Where Sun Meets Water

## FLOATING SOLAR MARKET REPORT

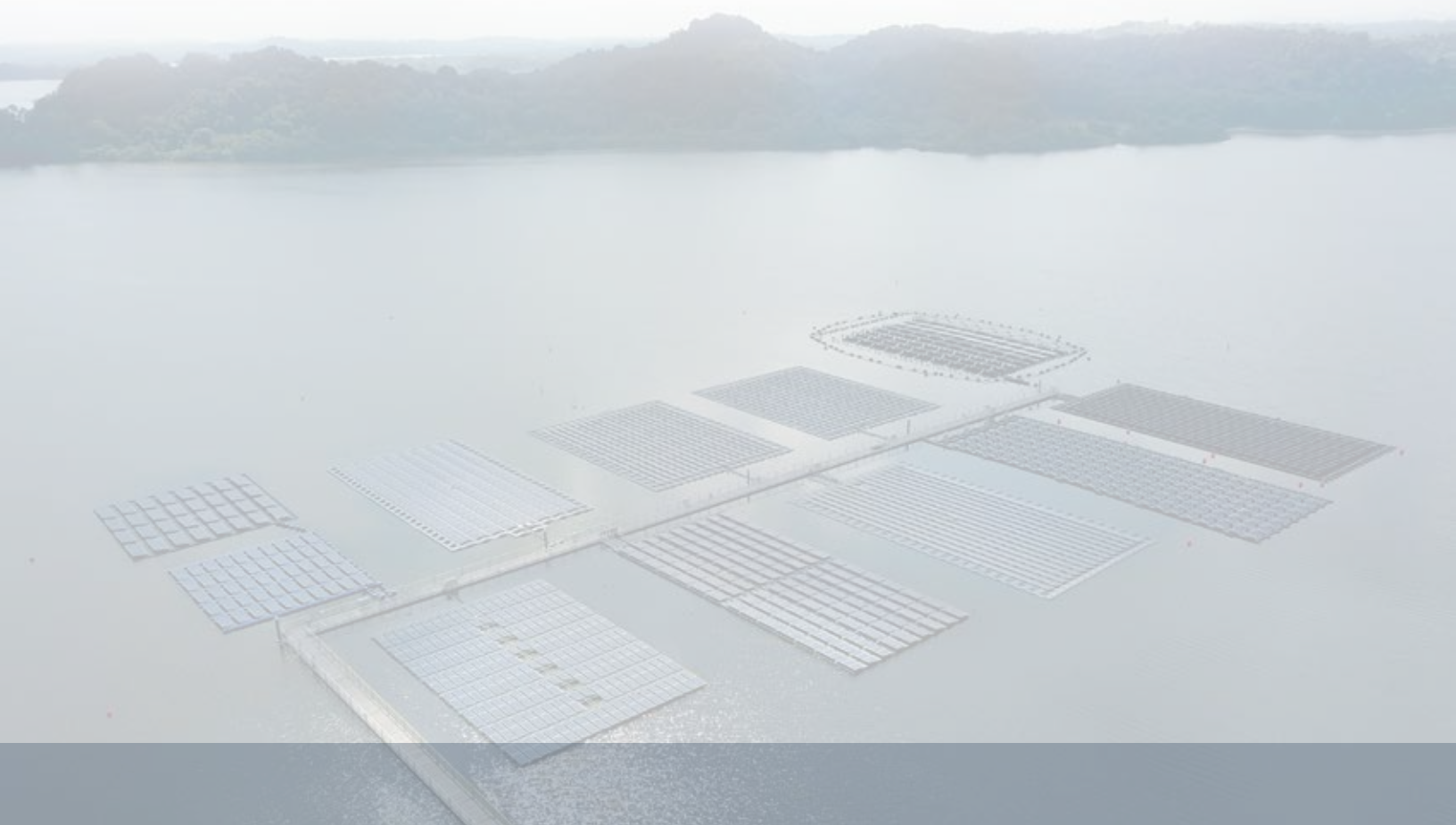

## **Energy Sector Management Assistance Program (ESMAP)**

The Energy Sector Management Assistance Program (ESMAP) is a global knowledge and technical assistance program administered by the World Bank. ESMAP assists low- and middle-income countries to increase their know-how and institutional capacity to achieve environmentally sustainable energy solutions for poverty reduction and economic growth. ESMAP is funded by Australia, Austria, Canada, Denmark, the European Commission, Finland, France, Germany, Iceland, Italy, Japan, Lithuania, Luxemburg, the Netherlands, Norway, the Rockefeller Foundation, Sweden, Switzerland, the United Kingdom, and the World Bank.

## **Solar Energy Research Institute of Singapore (SERIS)**

The Solar Energy Research Institute of Singapore (SERIS) at the National University of Singapore, founded in 2008, is Singapore's national institute for applied solar energy research. SERIS is supported by the National University of Singapore, National Research Foundation (NRF) and the Singapore Economic Development Board. It has the stature of an NUS University-level Research Institute and is endowed with considerable autonomy and flexibility, including an industry friendly intellectual property policy.

SERIS' multi-disciplinary research team includes more than 160 scientists, engineers, technicians and PhD students working in R&D clusters including (i) solar cells development and simulation; (ii) PV modules development, testing, certification, characterization and simulation; (iii) PV systems, system technologies, including floating PV, and PV grid integration. SERIS is ISO 9001 & ISO 17025 certified.

SERIS has extensive rich knowledge and experience with floating PV systems, including having designed and operating the world's largest floating PV testbed in Tengeh Reservoir, Singapore, which was commissioned by PUB, Singapore's National Water Agency, and the Economic Development Board. Launched in October 2016, this testbed compares side by side various leading floating PV solutions from around the world. Through detailed monitoring and in-depth analysis of performance of all the systems, SERIS accumulated deep insight into floating solar and SERIS' objective is to disseminate the best practices in installation and operation of floating solar plants as well as help to formulate standards for floating PV.

# CONTENTS

<b>E</b>	<b>EXECUTIVE SUMMARY</b>	<b>1</b>
<b>1</b>	<b>WHY FLOATING SOLAR?</b>	<b>15</b>
	1.1. The benefits of floating solar	18
	1.2. The effects of floating installations on water bodies	20
	1.3. Technological advantages of floating solar	21
	1.4. Challenges	23
	1.5. Comparison with ground-mounted systems	25
<b>2</b>	<b>TECHNOLOGY OVERVIEW</b>	<b>31</b>
	2.1 Key components and system designs	32
	2.2 Novel FPV concepts	41
	2.3 Hybrid operation with hydropower plants	48
<b>3</b>	<b>GLOBAL MARKET AND POTENTIAL</b>	<b>55</b>
	3.1 Availability of floating solar resource	55
	3.2 Current market status	58
<b>4</b>	<b>POLICY CONSIDERATIONS AND PROJECT STRUCTURING</b>	<b>81</b>
	4.1 Financial incentives and support mechanisms in selected countries	81
	4.2 Supportive governmental policies	82
	4.3 Other policy and regulatory considerations	84
	4.4 Business models and project structuring	85
<b>5</b>	<b>COSTS OF FLOATING SOLAR</b>	<b>91</b>
	5.1 Recent disclosed FPV costs	91
	5.2 Calculating the levelized cost of electricity	99
	5.3 Sensitivity analysis	103
	5.4 Risk assessment	104
	5.5 Conclusion	104
<b>6</b>	<b>SUPPLIERS OF FLOATING PV SYSTEMS</b>	<b>109</b>
	6.1 General overview	109
	6.2 Providers of floating technology solutions for inland freshwater applications	110
	6.3 Providers of floating technology solutions for offshore or near-shore applications	120

# ACRONYMS

AC	alternating current
ADB	Asian Development Bank
AGC	automatic generation control
BBC	British Broadcasting Corporation
CAPEX	capital expenditure
C&T	Ciel & Terre International
CIESIN	Columbia University Center for International Earth Science Information Network
DC	direct current
DR	discount rate
ESMAP	Energy Sector Management Assistance Program
EPCI	equity project cost investment
EJ	exajoules
FiT	feed-in tariff
FPV	floating PV
GIS	geographic information system
GWp	gigawatt-peak
GHI	global horizontal irradiance
GRanD	Global Reservoir and Dam Database
GWSP	Global Water System Project
HDPE	high-density polyethylene
IC	insurance cost
IEA	International Energy Agency
IFC	International Finance Corporation
IRENA	International Renewable Energy Agency
IEI	inverter warranty extension investment
km	kilometers
kV	kilovolt
kWh	kilowatt-hour
kWp	kilowatt-peak
LCOE	levelized cost of electricity
LP	loan payments
LSIS	LS Industrial Systems
MWh	megawatt-hours
MWp	megawatt-peak
NHI	Natural Heritage Institute
TU Delft	Netherlands' Delft University of Technology

O&M	operation and maintenance
PERC	passivated emitter rear cell
PR	performance ratio
PV	photovoltaic
REC	renewable energy certificate
SEAC	Solar Energy Application Center
SECI	Solar Energy Corporation of India
SERIS	Solar Energy Research Institute of Singapore
SMART	Solar Massachusetts Renewable Target
km <sup>2</sup>	square kilometers
SMCC	Sumitomo Mitsui Construction Co., Ltd.
SCADA	supervisory control and data acquisition
SDR	system degradation rate
MOIT	Vietnam's Ministry of Industry and Trade
Wp/m <sup>2</sup>	watt peak per square meter
WACC	weighted average cost of capital
WEC	World Energy Council

All dollar figures denote U.S. dollars unless otherwise noted





CHINA

© Sungrow



# EXECUTIVE SUMMARY

## FLOATING SOLAR MARKET REPORT

### Why floating solar?

Floating solar photovoltaic (FPV) installations open up new opportunities for scaling up solar generating capacity, especially in countries with high population density and competing uses for available land. They have certain advantages over land-based systems, including utilization of existing electricity transmission infrastructure at hydropower sites, close proximity to demand centers (in the case of water supply reservoirs), and improved energy yield thanks to the cooling effects of water and the decreased presence of dust. The exact magnitude of these performance advantages has yet to be confirmed by larger installations, across multiple geographies, and over time, but in many cases they may outweigh any increase in capital cost.

The possibility of adding FPV capacity to existing hydropower plants is of particular interest, especially in the case of large hydropower sites that can be flexibly operated. The solar capacity can be used to boost the energy yield of such assets and may also help to manage periods of low water availability by allowing the hydropower plant to operate in “peaking” rather than “baseload” mode. And the benefits go both ways: hydropower can smooth variable solar output by operating in a “load-following” mode. Floating solar may therefore be of particular interest where grids are weak, such as in Sub-Saharan Africa and parts of developing Asia.

Other potential advantages of FPV include:

- Reduced evaporation from water reservoirs, as the solar panels provide shade and limit the evaporative effects of wind
- Improvements in water quality, through decreased algae growth
- Reduction or elimination of the shading of panels by their surroundings
- Elimination of the need for major site preparation, such as leveling or the laying of foundations, which must be done for land-based installations
- Easy installation and deployment in sites with low anchoring and mooring requirements, with a high degree of modularity, leading to faster installations.

### An overview of floating solar technology

The general layout of an FPV system is similar to that of a land-based PV system, other than the fact that the PV arrays and often the inverters are mounted on a floating platform (figure E.1). The direct current (DC) electricity generated by PV modules is gathered by combiner boxes and converted to alternating current (AC) by inverters. For small-scale floating plants close to shore, it is possible to place the inverters on land—that is, just a short distance from the array. Otherwise, both central or string inverters on specially designed floats are typically used. The platform, together with its anchoring and mooring system, is an integral part of any FPV installation.

**FIGURE E.1** Schematic representation of a typical large-scale FPV system with its key components

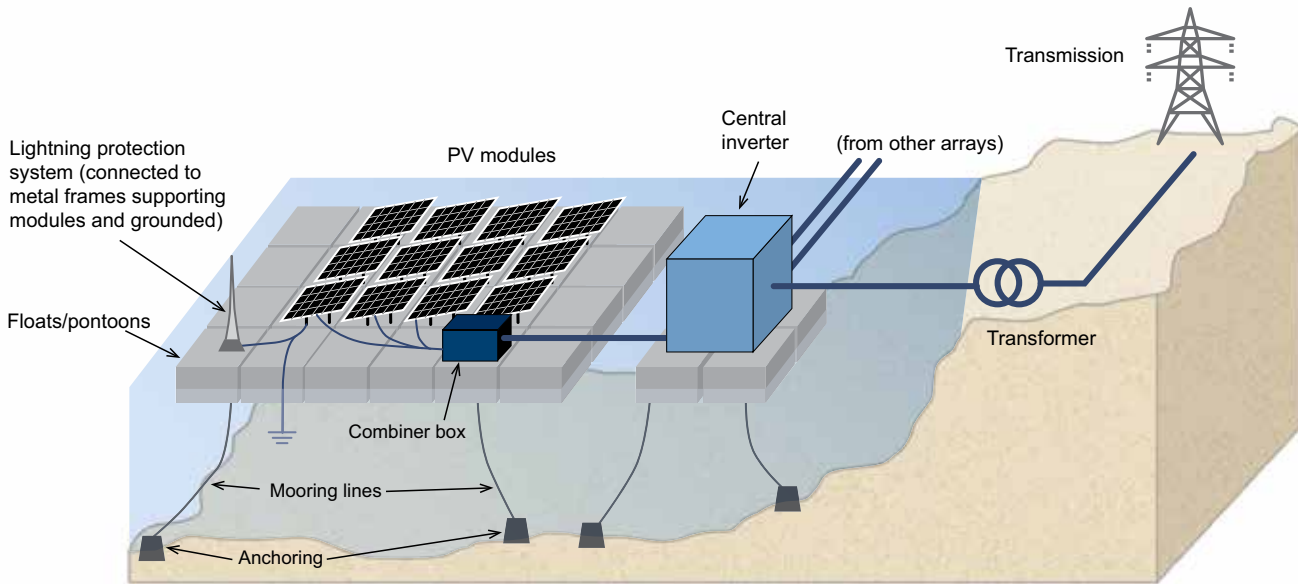

Source: Solar Energy Research Institute of Singapore (SERIS) at the National University of Singapore.

Currently most large-scale FPV plants are deployed using pontoon-type floats, with PV panels mounted at a fixed tilt angle. Typically, the floating structure can be made of so-called pure floats or floats that are combined with metal trusses (figure E.2). A pure float configuration uses specially designed self-buoyant bodies to which PV panels can be directly affixed. This configuration is the most common. It is available from several suppliers and has an installed capacity worldwide of several hundred megawatts. Another type of design uses metal structures to support PV panels in a manner similar to land-based systems. These structures are fixed to pontoons whose only function is to provide buoyancy. In this case, there is no need for specially designed floats. The floating platform is held in place by an anchoring and mooring system, the design of which depends on factors such as wind load, float type, water depth, and variability in the water level.

The floating platform can generally be anchored to a bank, to the bottom, to piles, or to a combination of the three. The developer selects a design suitable to the platform's location, bathymetry (water profile

and depth), soil conditions, and variation in water level. Bank anchoring is particularly suitable for small and shallow ponds, but most floating installations are anchored to the bottom. Regardless of the method, the anchor needs to be designed so as to keep the installation in place for 25 years or more. Mooring lines need to be properly selected to accommodate ambient stresses and variations in water level.

## The current global market for floating solar

The first FPV system was built in 2007 in Aichi, Japan, followed by several other countries, including France, Italy, the Republic of Korea, Spain, and the United States, all of which have tested small-scale systems for research and demonstration purposes. The first commercial installation was a 175 kWp system built at the Far Niente Winery in California in 2008. The system was floated atop a water reservoir to avoid occupying land better used for growing grapes.

Medium-to-large floating installations (larger than 1 MWp) began to emerge in 2013. After an initial wave of deployment concentrated in Japan, Korea, and the United States, the FPV market spread to China (now the largest player), Australia, Brazil, Canada, France, India, Indonesia, Israel, Italy, Malaysia, Maldives, the

Netherlands, Norway, Panama, Portugal, Singapore, Spain, Sweden, Sri Lanka, Switzerland, Thailand, Tunisia, Turkey, the United Kingdom, and Vietnam, among others. Projects are under consideration or development in Afghanistan, Azerbaijan, Colombia, Ghana, the Kyrgyz Republic, Myanmar, and Pakistan, among others.

**FIGURE E.2** The most common float types: pure float, Indonesia (top) and pontoons with metal structures, India (bottom)



Source: © Ciel & Terre International.



Source: © NB Institute for Rural Technology.

Recently, plants with capacity of tens and even hundreds of megawatts have been installed in China; more are planned in India and Southeast Asia. The first plant larger than 10 MWp was installed in 2016, and in 2018 the world saw the first of several plants larger than 100 MWp, the largest of which is 150 MWp. Flooded mining sites in China support most of the largest installations (box E.1). With the emergence of these new markets, cumulative installed FPV capacity

and annual new additions are growing exponentially (figure E.3).

As of December 2018, the cumulative installed capacity of floating solar was about 1.3 gigawatt-peak (GWp), the same milestone that ground-mounted PV reached in the year 2000. If the evolution of land-based PV is any indication, floating solar could advance at least as rapidly, profiting from all the decreases in costs

**FIGURE E.3 Global installed floating PV capacity and annual additions**

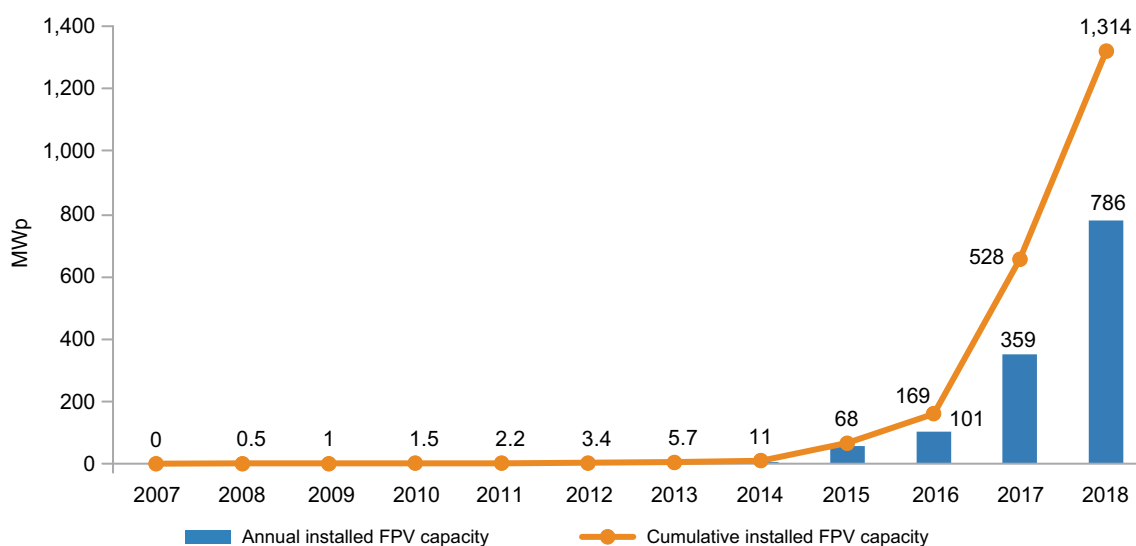

Source: Authors' compilation based on media releases and industry information.

### BOX E.1

## China's collapsed coal mines turned into a solar opportunity

There are dozens of flooded coal mines in China. Spurred by China's "Top Runner" program, solar developers are turning these environmental and social challenges into an opportunity. Anhui Province is home to the world's largest floating solar installations to date, ranging from 20 megawatts (MW) to 150 MW per site.

Local people who just a few years ago worked underground as coal miners are now being retrained

as solar panel assemblers and maintenance personnel. They are earning better wages and are no longer exposed to harmful mine conditions known to cause lung disease.

Producing solar power in mining regions while scaling back coal-based power production is one way to improve local air pollution in several regions of China.

Source: Authors' compilation based on Mason (2018) and BBC (2018).



attained by land-based PV deployment. Most of the installations to-date are based on industrial basins, drinking water reservoirs, or irrigation ponds (figure E.4), but the first combinations with hydropower reservoirs, which bring the added benefits of better utilization of the existing transmission infrastructure and the opportunity to manage the solar variability through

combined power output, have started to appear (box E.2). In these installations, special attention needs to be paid to possible effects on the downstream flow regime from the reservoir, which is typically subject to restrictions related to water management (in case of cascading dams), agriculture, biodiversity, navigation, and livelihood or recreational uses.

**FIGURE E.4** Floating solar installations in Malaysia (top), and Japan (bottom)



Source: © Ciel & Terre International.



Source: © Ciel & Terre International.

## BOX E.2

### Hydropower-connected solar PV systems

The development of grid-connected hybrid systems that combine hydropower and floating photovoltaic (PV) technologies is still at an early stage. Only a small system of 220 kilowatt-peak (kWp) has been deployed in Portugal (see photo) (Trapani and Santafé 2015). But many projects, and of much greater magnitudes, are being discussed or developed across the world.

The largest hybrid hydro-PV system involves ground-mounted solar PV. This is the Longyangxia hydro-connected PV power plant in Qinghai, China (Qi 2014), which is striking for its sheer magnitude and may be considered a role model for future hybrid systems, both floating and land-based.

The Longyangxia hydropower plant was commissioned in 1989, with four turbines of 320 megawatts (MW) each, or 1,280 MW in total. It serves as the major load peaking and frequency regulation power plant in China's northwest power grid. The associated Gonghe solar plant is 30 kilometers (km) away from the Longyangxia hydropower plant. Its initial phase was built and commissioned in 2013 with a nameplate capacity of 320 megawatt-peak (MWp). An additional 530 MWp was completed in 2015.

The PV power plant is directly connected through a reserved 330 kilovolt (kV) transmission line to the Longyangxia hydropower substation. The hybrid system is operated so that the energy generation of the hydro and PV components complement each other (Choi and Lee 2013). After the PV plant was added, the grid operator began to issue a higher power dispatch set point during the day. As expected, on a typical day the output from the hydro facility is now reduced, especially from 11 a.m. to 4 p.m., when PV generation is high. The saved energy is then requested by the operator to be used during early morning and late-night hours. Although the daily generation pattern of the hydropower has changed, the daily reservoir water balance could be maintained at the same level as before to also meet the water requirements of other downstream reservoirs. All power generated by the hybrid system is fully absorbed by the grid, without any curtailment. This system shows that hydro turbines can provide adequate response as demand and PV output varies.

*Source:* Authors' compilation based on Trapani and Santafé (2015); Qi (2014); and Choi and Lee (2013).

#### First-ever hydropower-connected FPV operation, Montalegre, Portugal



*Source:* © Pixbee/EDP S.A.

Marine installations are also appearing. The deployment of FPV technologies near shore may be of strong interest to populous coastal cities. Indeed, it may be the only viable way for small island states to generate clean solar power at scale, given the limited availability of land suitable for ground-mounted PV installations.

Still at a nascent stage, near-shore solar PV is conceptually similar to deployment on inland water bodies. But the offshore environment poses additional challenges:

- Water surface conditions are much rougher (larger waves and higher winds)
- Mooring and anchoring become even more critical amid large tidal movements and currents
- Salinity tests the durability of components
- The accumulation of marine organisms on equipment (“bio fouling”) can interfere with functionality.

The harsher near-shore environment imposes stringent requirements on floats, anchors, moorings, and components. Alternative design and technological solutions may be required, drawing on the rich experience of existing marine and offshore industries. Compared to the open sea, coastal areas such as lagoons and bays are relatively calm and thus more suitable for FPV, however installations must still be able to withstand waves and high winds. On the other hand, some lagoons and bays can be environmentally sensitive, which may limit the possibility for FPV deployment in certain areas.

The biggest uncertainties are long-term reliability and cost. Marine-grade materials and components are critical for these installations, which must withstand the prevailing environmental conditions. Operation and maintenance costs for near-shore PV are also expected to be higher than for inland installations.

In the Maldives, near-shore solar PV is powering a tourist resort; in Norway, a large fish farm (figure E.5). Future systems will likely fulfill needs that are additional to energy production, such as the generation of hydrogen or the solar-based desalination of water.

## Policy and regulatory considerations

Currently, even in countries with significant FPV development there are no clear, specific regulations on permitting and licensing of such plants. Processes for the moment are assumed to be the same as for ground-mounted PV, but legal interpretation is needed in each country. In some countries, drinking water reservoirs or hydropower reservoirs are considered national-security sites, making permitting more complex and potentially protracted.

As highlighted in this report, FPV deployment is expected to be cost-competitive under many circumstances and therefore not to require financial support. Nevertheless, initial projects may require some form of support to overcome barriers associated with the industry’s relatively limited experience with this technology.

So far, a number of countries have taken different approaches to FPV. Typical policies currently supporting FPV installations can be grouped into two categories:

### Financial incentives:

- Feed-in tariffs that are higher than those for ground-mounted PV (as in Taiwan, China)
- Extra bonuses for renewable energy certificates (as in the Republic of Korea)
- A high feed-in tariff for solar PV generally (as in Japan)
- Extra “adder” value for FPV generation under the compensation rates of state incentives program (as in the U.S. state of Massachusetts).

### Supportive governmental policies:

- Ambitious renewable energy targets (as in Korea and Taiwan, China)
- Realization of demonstrator plants (as in the Indian state of Kerala)

**FIGURE E.5** Near-shore floating installations in the Baa Atoll of the Maldives (left), and off the west coast of Norway, (right)



Source: © Swimsol.



Source: © Ocean Sun.

- Dedicated tendering processes for FPV (as in Taiwan, China and India)
- Openness on the part of the entities managing the water bodies, such as tenders for water-lease contracts (as in Korea).

However, for most countries hoping to develop a well-functioning FPV segment as part of their solar PV market development, the following policy and regulatory considerations need to be addressed:

- Unique aspects of permitting and licensing that necessitate interagency cooperation between energy and water authorities. This also includes environmental impact assessments for FPV installations.
- Water rights and permits to install and operate an FPV plant on the surface of a water body and anchor it in or next to the reservoir.
- Tariff setting for FPV installations (which could be done as for land-based PV, for example, through feed-in tariffs for small installations and tenders or auctions for large ones).
- Access to existing transmission infrastructure:
  - How will this be managed?
  - Who will be responsible?
  - What permits/agreements will be required?

- Special considerations for hydro-connected plants:
  - Whether the hydropower plant owner/operator is allowed to add an FPV installation
  - Whether the hydropower plant owner/operator is allowed to provide a concession to a third party to build, own, and operate an FPV plant
  - Management of risks and liabilities related to hydropower plant operation and weather events that can affect the solar or hydropower plants
  - Rules of dispatch coordination of the solar and the hydropower plants' outputs.

## Market opportunities

There are more than 400,000 square kilometers (km<sup>2</sup>) of man-made reservoirs in the world (Shiklomanov 1993), suggesting that FPV has a theoretical potential on a terawatt scale, purely from the perspective of the available surface area. The most conservative estimate of FPV's overall global potential based on available man-made water surfaces exceeds 400 GWp, which is equal to the 2017 cumulative installed PV capacity globally. Table E.1 provides a summary of the man-made freshwater bodies supporting this very conservative estimate. Considering global irradiance data on significant water bodies, and assuming 1 percent to 10 percent of their total surface area as used for FPV deployment, an estimate of potential peak capacity



**TABLE E.1. Peak capacity and energy generation potential of FPV on freshwater man-made reservoirs, by continent**

Continent	Total surface area available (km <sup>2</sup> )	Number of water bodies assessed	FPV potential (GWp)			Possible annual energy generation (GWh/year)		
			Percentage of total surface area used			Percentage of total surface area used		
			1%	5%	10%	1%	5%	10%
Africa	101,130	724	101	506	1,011	167,165	835,824	1,671,648
Middle East and Asia	115,621	2,041	116	578	1,156	128,691	643,456	1,286,911
Europe	20,424	1,082	20	102	204	19,574	97,868	195,736
North America	126,017	2,248	126	630	1,260	140,815	704,076	1,408,153
Australia and Oceania	4,991	254	5	25	50	6,713	33,565	67,131
South America	36,271	299	36	181	363	58,151	290,753	581,507
<b>Total</b>	<b>404,454</b>	<b>6,648</b>	<b>404</b>	<b>2,022</b>	<b>4,044</b>	<b>521,109</b>	<b>2,605,542</b>	<b>5,211,086</b>

Source: SERIS calculations based on the Global Solar Atlas © World Bank Group (2019) and the GRanD database, © Global Water System Project (2011).

Note: GWh = gigawatt-hour; GWp = gigawatt-peak; km<sup>2</sup> = square kilometers; PV = photovoltaic.

was derived using the efficiency levels of currently available PV modules and the surface area needed for their installation, operation, and maintenance. Then, to estimate potential electricity generation, the capacity estimate was multiplied by the expected specific energy yield, with local irradiance used alongside a conservative assumption of an 80 percent performance ratio. These estimates use very low ratio of coverage of the reservoir. In reality, many existing projects implemented on industrial or irrigation reservoirs cover much more significant portions of the reservoirs, after environmental studies confirm no expected impact on the aquatic life in the reservoirs. The situation from one reservoir to another can differ significantly, however.

There are individual dams on each continent that could theoretically accommodate hundreds of megawatts or, in some cases, gigawatts of FPV installations. Examples of such reservoirs are provided in table E.2. While hydropower and solar capacity do not provide the same type of power production (solar typically has a lower capacity factor and generates variable power), the table compares the surface needed for a PV plant having the same peak capacity as the hydropower reservoir.

## Costs of floating solar and project structuring

### Capital costs

The capital costs of floating PV are still slightly higher or comparable to those of ground-mounted PV, owing chiefly to the need for floats, moorings, and more resilient electrical components. The cost of floats is expected to drop over time, however, owing to better economies of scale.

Total capital expenditures for turnkey FPV installations in 2018 generally range between \$0.8–1.2 per Wp (figure E.6), depending on the location of the project, the depth of the water body, variations in that depth, and the size of the system. China is the only country that has yet built installations of tens to hundreds of megawatt-peak in size. The costs of smaller systems in other regions could vary significantly.

As reflected in figure E.6, Japan remains a region with relatively high system prices, while China and India achieve much lower prices, a pattern that can also be seen in ground-mounted and rooftop solar systems when compared to the global average.

**TABLE E.2. Reservoir size and estimated power generation capacity of selected hydropower dams, and potential of FPV to match the dams' hydropower capacity**

Dam/reservoir	Country	Reservoir size (km <sup>2</sup> )	Hydropower (GW)	Percentage of reservoir area required for FPV to match dam's hydropower capacity (%)
Bakun Dam	Malaysia	690	2.4	3
Lake Volta	Ghana	8,500	1.0	<1
Guri Dam	Venezuela	4,250	10.2	2
Sobradinho "Lake"	Brazil	4,220	1.0	<1
Aswan Dam	Egypt	5,000	2.0	<1
Attaturk Lake and Dam	Turkey	820	2.4	3
Narmada Dam	India	375	1.5	4

Source: Authors' compilation.

Note: GW = gigawatt; km<sup>2</sup> = square kilometer; PV = photovoltaic

**FIGURE E.6 Investment costs of FPV in 2014–2018 (realized and auction results)**

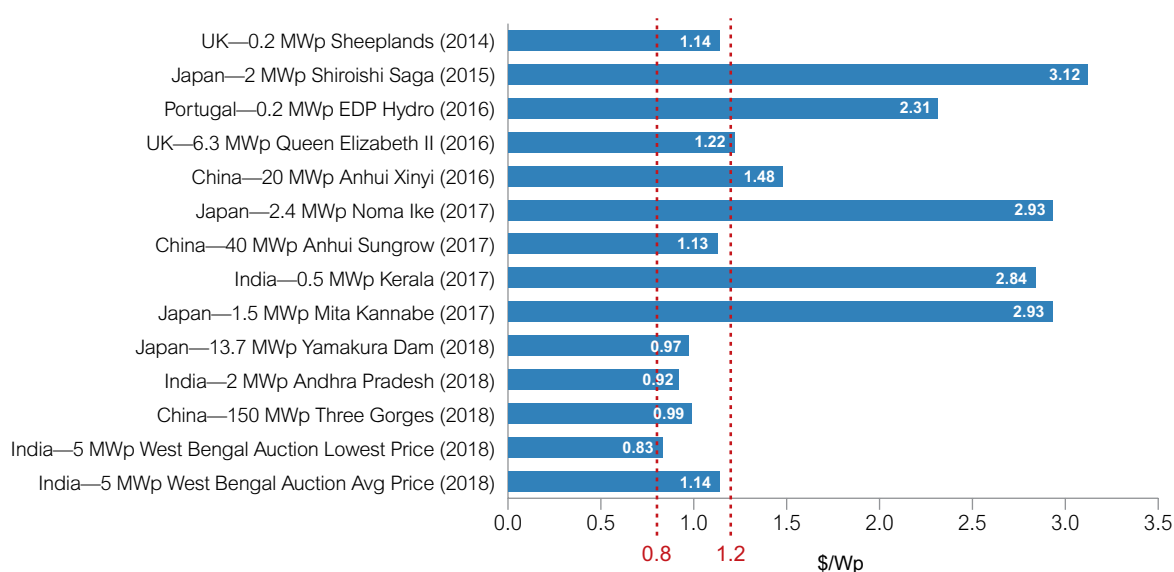

Source: Authors' compilation based on media releases and industry information.

Note: Using the 2017 \$ annual exchange rates, as released by OECD. PV = photovoltaic; \$/Wp = U.S. dollars per watt-peak.

### Levelized costs of electricity, including sensitivity analysis

Calculated on a pretax basis, the levelized cost of electricity (LCOE) for a generic 50 MW FPV system does not differ significantly from that of a ground-mounted system. The higher initial capital expenditures of the floating system are balanced by a higher expected energy yield—calculated for

a conservative and optimistic scenario. This result holds at a range of discount rates, as shown in table E.3. Both projects have the same theoretical financial assumptions and irradiance. However, the main differentiating factors are system price (a floating system is considered 18 percent more expensive), and performance ratio (5–10 percent higher for floating systems).

**TABLE E.3. Results of (pre-tax) calculations of the LCOE of FPV vs. ground-mounted PV**

LCOE (\$cents/kWh)			Ground-mounted PV 50 MWp	Floating PV 50 MWp	
				Conservative (+5% PR)	Optimistic (+10% PR)
Tropical	WACC	6%	6.25	6.77	<b>6.47</b>
		8%	6.85	7.45	<b>7.11</b> base case
		10%	7.59	8.28	<b>7.91</b>
Arid/desert	WACC	6%	4.52	4.90	<b>4.68</b>
		8%	4.96	5.39	<b>5.15</b>
		10%	5.51	6.01	<b>5.74</b>
Temperate	WACC	6%	6.95	<b>7.53</b>	7.19
		8%	7.64	<b>8.30</b>	7.93
		10%	8.49	<b>9.26</b>	8.85

Source: SERIS calculations.

Notes: kWh = kilowatt-hour; LCOE = levelized cost of electricity; MWp = megawatt-peak; PV = photovoltaic; WACC = weighted average cost of capital. The bold LCOE values are the “more likely” cases per type of climate.

The LCOE calculation represents only a break-even analysis—that is, if the tariff were set at the LCOE, the net present value of the project would be zero.<sup>1</sup> Equity investors would presumably require a higher tariff from the offtaker to make the project economically viable for them, assuming debt financing was accessible.

If the performance ratio of an FPV project is assumed to be 10 percent higher than that of a ground-based project (instead of 5 percent), a sensitivity analysis shows that the LCOE is only 3-4 percent higher than the one for the ground-mounted system.

### Project structuring

To understand how FPV projects are typically financed, it is useful to classify them into two main categories: those with an installed capacity of 5 MWp or lower, and those with an installed capacity greater than 5 MWp. Table E.4 summarizes typical financial structures for these categories, which are similar to financial structures for land-based PV deployment. To gain trust in the technology, public grants are often provided to finance R&D and pilot projects (<1 MWp), which are often run by universities or public research institutions.

1. The discounted payback period is 20 years, and the equity internal rate of return is set at the discount rate.

Given their small size (except in China), most FPV projects are financed in local currencies and mainly by local or regional banks. Japan, Taiwan, China and a few other economies have seen an increased involvement of local commercial banks seeking to take advantage of favorable long-term feed-in tariffs available for FPV. The involvement of large international commercial banks, and of multilateral development finance institutions in developing countries, is expected to grow as larger projects become more common in areas outside China.

### Challenges

While enough large-scale projects have been implemented to show the commercial viability of FPV, there are remaining challenges to its deployment—among them the lack of a robust track record; uncertainty surrounding costs; uncertainty about predicting environmental impact; and the technical complexity of designing, building, and operating on and in water (especially electrical safety, anchoring and mooring issues, and operation and maintenance). The experience of other technologies operating in aquatic environments, including near-shore environments, offers good lessons in some of these areas.

**TABLE E.4. Financing structure vs. size of FPV system**

System size (MWp)	Business model	Ownership	Financing structure
≤ 5	Self-generation	Commercial and industrial companies	Pure equity and/or corporate financing (or “on balance sheet” financing). Owner would typically be an energy-intensive commercial or industrial company with ponds, lakes, or reservoirs on its premises and willing to install an FPV system for its own use.
> 5	Power sold to the grid	Independent power producers and public utilities	Mix of debt and equity (typically 80:20); on balance sheet or non-recourse project finance. The latter is still rare, however, because such project finance structures make sense only for projects of a certain size (generally larger than 10 MWp). Future large projects will likely have financing structures similar to the ones used for utility-scale ground-mounted PV projects.

Source: Authors' compilation.

In addition to the technical aspects, challenges related to permitting and commercial aspects include: a lack of clarity on licensing/permitting (especially concerning water rights and environmental impact assessment); difficulties in selecting qualified suppliers and contractors; difficulties in designing insurance policies that include for example liabilities for potential damage of hydropower plant (when combined with such plant); and uncertainties about the adequacy of warranties of the performance or reliability of critical components. In most countries, the policy and regulatory framework needs to be adjusted to provide more clarity in some of these areas.

## Conclusions and next steps

FPV deployment appears likely to accelerate as the technologies mature, opening up a new frontier in the global expansion of renewable energy and bringing opportunities to a wide range of countries and markets. With a global potential of 400 GW under very conservative assumptions, FPV could double the existing installed capacity of solar PV but without the land acquisition that is required for ground-mounted installations. At some large hydropower plants, covering just 1–4% of the reservoir with FPV could double the installed capacity, potentially allowing water resources to be more strategically managed by utilizing the solar output during the day. Additionally, combining the dispatch of solar and hydropower could be used to smooth the variability of the solar

output, while making better use of existing transmission assets, and this could be particularly beneficial in countries where grids are weak.

When combined with other demonstrated benefits such as higher energy yield, reduced evaporation, and improved water quality, FPV is likely to be an attractive option for many countries. Although the market is still nascent, there is a sufficient number of experienced suppliers to structure a competitive tender and get a commercial project financed and constructed, and the additional costs appear to be low and are falling rapidly.

The priority over the next few years should be to carry out strategic deployments of FPV at sites where it is already economic, while applying the “precautionary principle” when it comes to possible environmental or social impacts. This may include initial limits on the portion of the water surface that is covered and efforts to avoid installations in the littoral zone near shore, where plant and animal life may be more abundant. In addition, development of the constituent technologies and knowledge of positive and negative impacts will be greatly enhanced if early installations are diligently monitored, which will entail some public expenditure. The need for monitoring, added to the possible additional capital costs of FPV over those of ground-mounted systems, and the risk profile of FPV, given its early stage of deployment, make early installations in developing countries a strong candidate for concessional climate financing.



To support market development, an active dialogue among all stakeholders, public and private, is required to further global understanding of FPV technologies and to spread lessons learned from early projects across a wider area. Through this market report and an upcoming handbook for practitioners, the World Bank Group and SERIS hope to contribute to this goal, and we look forward to working with governments, developers, and the research community to expand the FPV market by bringing down costs, supporting grid integration, maximizing ancillary benefits, and minimizing negative environmental or social impacts.

In addition to the financing of public and private investments, the World Bank Group is committed to supporting the development of floating solar as well as hydro-connected solar by generating and disseminating knowledge. Publications and tools planned for the *Where Sun Meets Water* series are:

- An FPV market report executive summary
- An FPV market report
- An FPV handbook for practitioners
- Global mapping of FPV potential (a geospatial tool)
- Proposed technical designs and project structuring for hydro-connected solar.

---

## References

- BBC (British Broadcasting Corporation). 2018. "Solar Farm Means 'I Can Breathe More Easily.'" Video story, BBC News, April 24. <https://www.bbc.co.uk/news/av/business-43881280/solar-farm-means-i-can-breathe-more-easily>.
- Choi, Y.-K., and N.-H. Lee. 2013. "Empirical Research on the Efficiency of Floating PV Systems Compared with Overland PV Systems." *CES-CUBE* 25: 284–89.
- Global Solar Atlas: <https://globalsolaratlas.info/>, World Bank Group (2019).
- Lehner, B., C. Reidy Liermann, C. Revenga, C. Vörösmarty, B. Fekete, P. Crouzet, P. Döll, M. Endejan, K. Frenken, J. Magome, C. Nilsson, J. C. Robertson, R. Rodel, N. Sindorf, and D. Wisser. 2011a. "Global Reservoir and Dam Database, Version 1 (GRanDv1): Reservoirs, v1.01." NASA Socioeconomic Data and Applications Center (SEDAC), Palisades, NY. <http://sedac.ciesin.columbia.edu/data/set/grand-v1-reservoirs-rev01>.
- . 2011b. "High-Resolution Mapping of the World's Reservoirs and Dams for Sustainable River-Flow Management." *Frontiers in Ecology and the Environment* 9: 494–502.
- Mason, Pauline. 2018. "Meet the Ex-Miners Who Are Now Walking on Water." BBC News, April 27. <https://www.bbc.co.uk/news/business-43864665>.
- Qi, S. 2014. *The Analysis of Complementation in PV Grid-Connected Part of Longyangxia 320 MWp*, in *Engineering*. Xi'an: University of Technology.
- Shiklomanov, Igor A. 1993. "World Fresh Water Resources." In *Water in Crisis: A Guide to the World's Fresh Water Resources*, edited by Peter H. Gleick. New York: Oxford University Press.
- Sungrow: [https://en.sungrowpower.com/reference?id=22&ref\\_cate\\_id=30](https://en.sungrowpower.com/reference?id=22&ref_cate_id=30).
- Swimsol: <https://swimsol.com/>.
- Trapani, K., and M. Redón Santafé. 2015. "A Review of Floating Photovoltaic Installations: 2007–2013." *Progress in Photovoltaics: Research and Applications* 23 (4): 524–32.



# 1 WHY FLOATING SOLAR?

The amount of solar energy reaching the earth is tremendous. At noon, it can be more than 1,000 watts per square meter ( $W/m^2$ ). The total solar energy received over the course of a year is about 3,400,000 exajoules (EJ). This is roughly 7,500 times the world's annual primary energy consumption of about 450 EJ (WEC 2013). There are two main ways to harvest solar energy, via solar heat and solar photovoltaics (PV). In PV generation, a device called a solar cell is used to turn light directly into electricity. The direct current (DC) generated by an array of solar modules (solar cells grouped and packaged together) then goes into an inverter, where it is converted to alternating current

(AC) to be fed into the power grid. The typical configuration of a grid-connected PV power plant is shown in figure 1.1.

The PV industry is developing fast. Thanks to technological advancement and an increasing scale of production, the cost of solar cells and modules has come down drastically over recent years. Solar PV modules were more than 80% cheaper in 2017 than they were in 2009 and the cost of electricity from solar PV fell by almost three-quarters in 2010–2017 and continues to decline (IRENA 2018). Fueled by falling prices, the cumulative installed capacity of PV grew significantly

**FIGURE 1.1** General configuration of a photovoltaic power plant

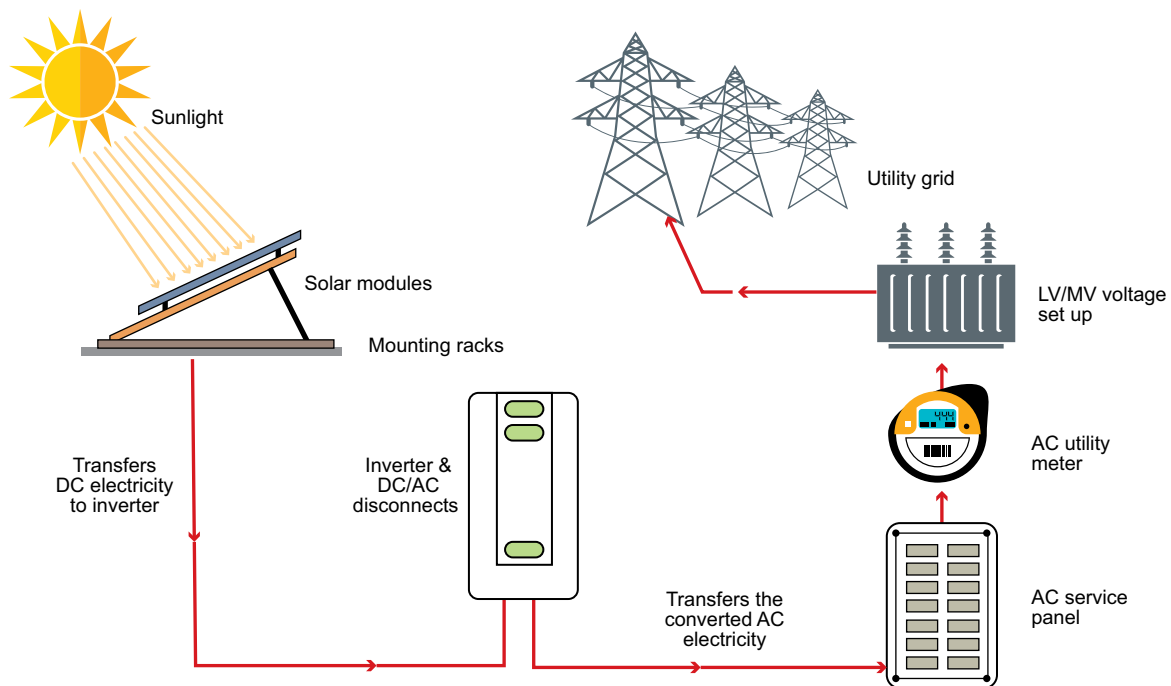

Source: Adapted from IFC 2015.

Note: AC = alternating current; DC = direct current; LV = low voltage; MV = medium voltage.

over the past years and by the end of 2018 stood at about 500 GWp (IEA 2018). Record new photovoltaic capacity was added in 2018, breaking the 100 GWp barrier for the first time (BNEF 2019). The vast majority of installations are either ground-mounted (often in large solar farms of tens to hundreds of megawatts, MW) or on rooftops of commercial/industrial buildings (where installations are also often on a megawatt scale) or private residences (with kilowatt scale installations).

Spurred by the high cost or limited availability of land in countries such as Japan, the Republic of Korea, and Singapore, the PV industry has started to look into using water bodies for PV applications. This has the added benefit of allowing the deployment of large PV installations near load centers, thereby reducing the cost of transmission infrastructure.

The term *floating PV* (FPV) may be used to refer to any type of PV system installed on water bodies, such as lakes, reservoirs, hydroelectric dams, mining ponds, industrial and irrigation ponds, water treatment ponds, and coastal lagoons. Figure 1.2 shows two examples of FPV systems. In most cases, PV panels are usually mounted on a pontoon-based floating structure. The floating platforms are anchored and moored at a fixed location. In this report, we distinguish FPV from another form of PV deployment that may be called “PV over water” and involves mounting PV panels on piles above

shallow water bodies. This report will only briefly discuss this type of system.

Floating solar has the potential to become a third pillar of PV deployment and application, complementing ground-mounted (or land-based) PV and rooftop PV. There are more than 400,000 square kilometers (km<sup>2</sup>) of man-made reservoirs in the world (Shiklomanov 1993), suggesting that FPV has a deployment potential on a terawatt scale. Apart from saving land, benefits include greater efficiency and cost savings. These and other benefits will be discussed in this chapter, along with a number of challenges that remain to be addressed.

The first FPV system was built in 2007 in Aichi, Japan. Since then, many such projects have been installed, with the largest to be found in China, Japan, and Korea, and also Taiwan, China, the United Kingdom, India, the United States, and Cambodia. Smaller systems (with peak capacity below 2 megawatts, or megawatts-peak, MWp) have also been installed in countries such as Australia, Belgium, Brazil, Chile, Colombia, France, Germany, Indonesia, Israel, Italy, Malaysia, the Netherlands, Panama, Philippines, Portugal, Singapore, Spain, Sweden, Thailand, and Tunisia. Many of these smaller systems were set up for research and demonstration purposes. Novel arrangements such as submerged and concentrated PV systems are also being tested in

**FIGURE 1.2** Examples of floating photovoltaic systems: 150MWp in Guqiao, China (left) and 10 kWp system in Kunde winery, California, United States (right)



Source: © Sungrow.  
Note: kWp = kilowatt-peak; MWp = megawatt-peak.



Source: © World Bank.



some places. The first commercial installation of FPV is a 175 kilowatt-peak (kWp) system set up at the Far Niente Winery, California, United States, in 2008. This utilizes an irrigation pond to avoid occupying land better used for growing grapes. Good reviews of early-stage FPV projects and technologies can be found in several studies, including those of Connor (2009), Trapani and Santafé (2015); Patil, Wagh, and Shinde (2017); and Sahu, Yadav, and Sudhakar (2016). Beginning in 2013, FPV installations larger than 1 MWp started to emerge, mainly in Japan and Korea, then in China. Interest in FPV has since grown rapidly: large FPV plants (i.e., with peak capacity in the tens and even hundreds of megawatts) are being installed or planned around the world,

and especially in China and Southeast Asia (PV-Tech 2017a, 2017b; Maisch 2017) but many tenders for floating solar are also announced in India (Saurabh 2016, Kenning 2017, Kenning 2018, Sivakumar 2019). Eastern China, for example, is highly populated and has limited available land but abundant water bodies. In Southeast Asia, meanwhile, FPV could unlock the huge additional capacity of the region's many existing hydropower plants, for example, along the Mekong River. As these and other new markets emerge, cumulative installed FPV capacity and new additions are growing rapidly (figure 1.3). Table 1.1 summarizes some important milestones in FPV installations' early development stages (Planair and PITCO 2017).

**FIGURE 1.3 Global installed floating PV capacity and annual additions**

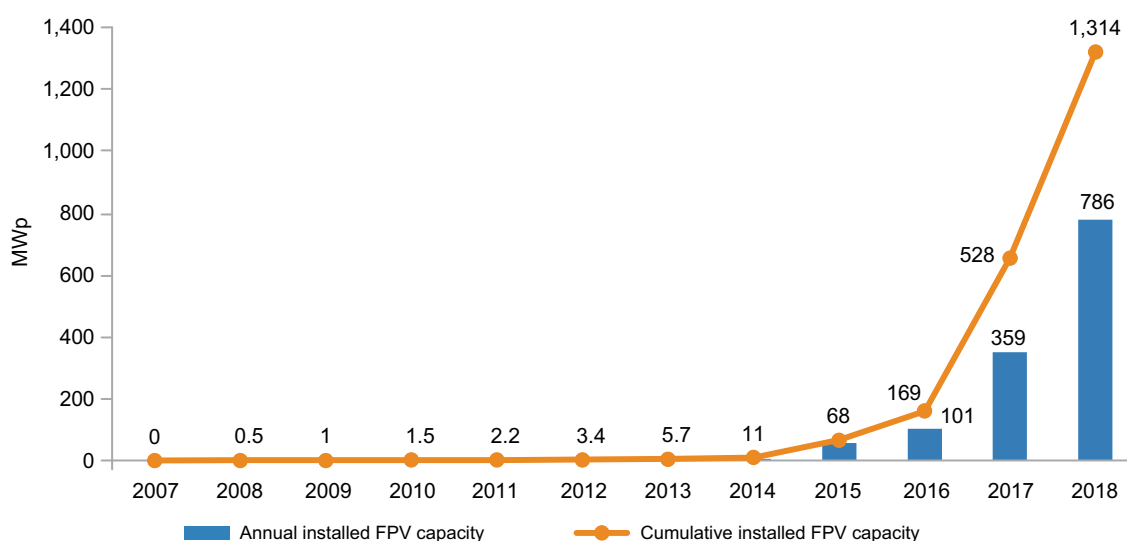

Source: Authors' compilation based on media releases and industry information.

**TABLE 1.1 Milestones in the early development of FPV installations**

Milestones	Installation
First FPV installation	20 kWp in Aichi Province, Japan (2007)
First nonresearch FPV installation	175 kWp at Far Niente Winery, United States (2008)
First tracking FPV installation	200 kWp Petra Winery (rotating system), Italy (2010)
First MW-scale FPV installation	1,180 kWp in Saitama Prefecture, Japan (2013)
First FPV installation using micro-inverters	300 kWp in Fukuoka Prefecture, Japan (2016)
First FPV combining solar and hydro	220 kWp at the Alto Rabagão Dam, Portugal (2017)

Source: Planair and PITCO 2017.

Note: FPV = floating photovoltaic; kWp = kilowatt-peak; MW = megawatt.



## 1.1. The benefits of floating solar

### 1.1.1. Land-use advantages of FPV

For countries where land is scarce or unsuitable for PV installations, the cost of building ground-mounted PV power plants is driven upward by high land prices and high opportunity costs. This is particularly pertinent to small countries, or where a mountainous terrain is unsuitable for the deployment of PV or the opportunity cost of using land is high (because of agriculture or urban development, for example). In countries such as Japan or Singapore, large-scale ground-mounted PV installations take up precious real estate.

Even where large swathes of open land are available for the installation of PV modules, these may be far from populated areas where energy demand is high. To deploy PV in remote areas requires transmitting energy over long distances, using high voltage transmission lines, to the residential or industrial areas where energy is actually needed. This is both costly and inefficient, especially since a certain percentage of the solar energy is lost in transmission. This is the situation in western China, where wind and solar resources are abundant and land is available at almost no cost, but the generated solar power cannot be utilized in nearby regions and requires long transmission lines that are often only partially built. Curtailments of up to 20–22 percent have been reported in Gansu and Xinjiang, for instance (National Energy Administration 2017), affecting investors' returns and confidence alike. On the other hand, deploying PV in or near populated areas is costly, since land here has a higher opportunity cost, and a higher real cost. In Taiwan, China, ground-mounted PV projects are restricted by the government because they compete with agriculture.

In such cases, the advent of FPV offers a viable and much-needed solution. It utilizes water surfaces that otherwise may not serve any economic, ecological,

or recreational purpose. In many cases, these can be used at low or no cost, unlike land, which must typically be leased or purchased.

To discourage solar PV farms from competing with land for other uses (such as agriculture) and to encourage the utilization of idle water bodies, some countries or regions offer financial incentives for deploying PV on water. For example, the government in Taiwan, China has implemented a feed-in-tariff regime that favors floating installations over ground-mounted PV. In Massachusetts (United States), an extra “adder” value under the compensation rates of state incentives program is available for FPV systems, while in Korea a higher renewable energy certificate (REC) weighting is given to FPV systems than for ground-mounted ones. Such incentives will be discussed in further detail in chapter 4.

### 1.1.2. Possibility to utilize hard-to-access terrain

Ground-mounted PV may not be possible to deploy, for example, in mountainous regions but even here floating systems can be set up on man-made lakes or reservoirs.

For instance, a test installation will be constructed on a hydropower dam in the Swiss Alps, at an altitude of 1,800 meters (figure 1.4). The potential for boosting the performance of dams at high altitudes is great. PV panels can benefit from the usually clear skies seen at these altitudes, the extreme cooling effect, as well as snow reflection. A land-based test installation in the Alps produces an estimated 50 percent more power than it would at a lower altitude (Romande Energie, 2018).

However, similarly to a ground-mounted PV system in harsh operating environment, a floating system must be designed to withstand the challenges that can be brought by such environment, including a frozen water surface, snow coverage of panels, and possible large fluctuations in water levels.

**FIGURE 1.4.** Visualization of a future pilot plant on a hydropower dam in the Swiss Alps in winter (top) and summer (bottom)



Source: © Romande Energie.



Source: © Romande Energie.

## 1.2. The effects of floating installations on water bodies

### 1.2.1. Integration with aquaculture and other applications

Floating solar installations can improve the economic value of water bodies, in particular in reservoirs where the water surface is left unused. In other cases, FPV can be combined with other productive uses, to increase profit and efficiency.

For example, FPV can be added to pond-based or other types of fisheries, where it can replace the diesel generators typically used for auxiliary services (e.g., oxygen pumps, lighting). “PV over water” installations, where panels are mounted on piles, are favored in China in installations that combine PV and aquaculture (figure 1.5). Adding PV to aquaculture has been accomplished at several sites of the so-called Top Runner program, initiated by the Chinese government to demonstrate and explore advanced PV technologies. This option is restricted to shallow waters, and for the purposes of this report is not considered FPV.

Combining floating solar with fish farming is explored in Norway and Singapore in near-shore conditions (figure 1.6). Power supply to fish farms provided by floating solar presents various advantages as fishes only eat during the day and less during winter, periods which are highly compatible with solar power output to provide the required electricity to the fish feeders.

**FIGURE 1.5.** A “PV over water” installation



Source: © Jinko Power.

The industry expects that in the future offshore FPV will be integrated not only with fish farming but also with other offshore applications such as water desalination, oil and gas exploration, shipping, data centers’ cooling, or even hydrogen production.

### 1.2.2. Reduced water evaporation

Evaporation represents a significant loss of water resources worldwide, with reported values as high as 40 percent (Helfer, Lemckert, and Zhang 2012; Santafé and others 2014). Reducing water evaporation is critical, especially in countries where water is scarce. Covering parts of a water body’s surface with FPV panels is an efficient way to reduce evaporation from drinking water reservoirs or irrigation ponds, even as it generates green electricity (figure 1.7).

The shade provided by floating panels not only reduces the amount of solar radiation reaching the water, but also limits the effects of wind on the water surface, which are part of the evaporation process. However, quantifying the extent of evaporation reduction is difficult, especially since FPV plants typically cover only part of the entire water surface. Rigorous studies are needed that utilize long-term reservoir operation data, including water level variations, rainfall, inflow, and outflow.

### 1.2.3. Water quality and other potential environmental impacts

Floating solar is considered environmentally benign. Most floats used to support PV panels are made of

**FIGURE 1.6.** Floating solar for fish farming in Singapore



Source: © Ocean Sun.



**FIGURE 1.7. FPV system for covering of entire reservoir surface to reduce water evaporation**



Source: © ISIGENERE.

a plastic material called high-density polyethylene (HDPE), which is used in drinking water applications (e.g., pipes) and does not degrade or contaminate the water. However, manufacturers' claims should always be tested, especially where a drinking-water reservoir is involved. There are no international, standardized testing procedures for floats, but some countries (e.g., China) are developing their own certification programs. Many manufacturers conduct relevant tests during the product design phase and can provide the relevant test results. Related best practices will be described in the next publication of *Where Sun Meets Water* series<sup>1</sup>, to follow shortly after this publication.

In addition, FPV discourages algae growth and could, in certain cases, improve water quality. Algae growth is significant in many reservoirs, and can increase the cost of treating water. Uncontrolled growth can have severe consequences for a lake's ecological balance. For example, in Lake Taihu, China, 2007, significant algae growth lowered water quality and led to the death of aquatic life (Qin and others 2010). City residents, too, were affected by the foul smell of the drinking water drawn from that lake. Algae growth is affected by several factors, such as water temperature and light intensity. It is reasonable to assume that by covering part of a reservoir's surface with PV panels, its growth can be curbed since there will be less

1. World Bank Group, ESMAP and SERIS. 2019. "Where Sun Meets Water: Floating Solar Handbook for Practitioners." Forthcoming. Washington DC: World Bank.

light for photosynthesis and less heat penetrating the water surface.

However, there may be adverse environmental impacts of blocking sunlight. Local studies are needed to understand the possible interactions between FPV installations and the water environment. Implications will also differ by the use of the water body. For example, natural lakes have a higher rate of bioactivity than industrial ponds used to cool water. In cases where an adverse impact is expected, the maximum surface to be covered by floating panels should be limited.

### 1.3. Technological advantages of floating solar

Besides saving land resources and potentially better use of water surfaces, FPV has some attractive technical benefits. These are mainly related to design and deployment, and power system performance/yield. Note that while some advantages have been proven to a certain degree, others remain conceptual.

#### 1.3.1. Increased energy yield

One of the important advantages of deploying PV on water is arguably the performance benefit derived from the operating environment. There are four key elements of this:

- The evaporative cooling effect of the water tends to lower the operating temperatures of the PV modules. A study of an FPV testbed in Singapore indicates that the ambient air temperature on water is lower by about 1°C to 3°C than the adjacent land environment (Liu and others 2018). This enables a lower operating temperature for PV modules. The cooling of PV modules is also more effective thanks to a higher temperature gradient and thus faster heat transfer. As a result, module temperatures were observed to be lower by 5°C to 10°C, depending on the air ventilation underneath the floating structures. In cases where the module is in good thermal contact with water, the cooling effect can be even greater. Since elevated module temperatures are a major loss factor for PV sys-

tems in many climates, a reduction in temperature can significantly increase the energy yield of a given installed PV capacity.

- The wind speeds over open water tend to be higher than over land, thus facilitating module cooling.
- Plants on water bodies are rarely shaded by nearby objects or buildings. Since the tilt angles of FPV arrays are usually kept low to reduce wind loads, the inter-row shading is also reduced.
- Water bodies tend to be less dusty than the arid desert locations where solar farms are often constructed, thus minimizing the effects and complications of dust gathering on panels.

Some early FPV projects reported an improved energy yield of more than 10 percent over that of ground-mounted PV systems (Trapani and Santafé 2015; Choi and Lee 2013). It is reasonable to expect that this benefit is highest in warm climates. More details about the cooling effect will be discussed in chapters 2 and 5.

### **1.3.2. Synergy with existing electrical infrastructure**

Many inland freshwater bodies, especially the reservoirs of hydropower plants, have nearby grid connections. As a result, the length of medium-voltage lines required to connect FPV to the grid is likely to be short. This can reduce investment in electrical infrastructure. In the case of large irrigation reservoirs, water treatment plants, cooling ponds for industrial use, or other energy-intensive infrastructure, the on-site self-consumption of the electricity produced by the installed FPV plants would further decrease costs and energy losses.

The existence of electrical infrastructure is location and project specific. Depending on the situation, FPV project developers need to make proper arrangements for the metering and integration of electrical systems. They also need to check relevant regulatory provisions, e.g., for self-consumption or net metering.

### **1.3.3. Complementary operation with hydropower**

There is great potential worldwide for the combined and integrated operation of hydropower stations and FPV. Usually dry seasons with less water flow correspond to periods of high solar insolation and vice versa. A hybrid of the two would thereby reduce seasonal variations in power production. In addition, the natural variability of solar radiation can be largely compensated by fast-responding hydro turbines. This improves power quality and reduces power curtailment. Also, a hybrid system can optimize the diurnal cycle by leveraging more solar power during the day and hydropower at night.

In hybrid systems, a reservoir is basically used as a giant storage facility for the variable, nondispatchable solar power. Retrofitting existing hydropower plants with new FPV projects would benefit from (i) skilled staff on site, and (ii) supervisory control and data acquisition (SCADA) systems developed for hydropower plants. More details on this will be provided in chapter 2.

### **1.3.4. Easier installation and deployment**

In cases where complicated anchoring and mooring are not required (see also section 1.4), the process of installing FPV is in many cases simpler than for ground-mounted PV. No civil work is needed to prepare the site, since typical floating platforms in the market are modular, made of small individual floats per module and interconnecting units. They do not require heavy equipment during construction. The platforms are assembled on land and get pushed into the water as the number of rows increases (figure 1.8 top). Thereafter they get towed to an exact location on the reservoir (figure 1.8 bottom). In sum, deployment times are shorter, and costs lower, than for ground-mounted PV. For example, a major FPV developer from China recently reported that a 1 MWp system can be installed by 50 people in one day, provided that a supply chain is in place. Installation and deployment will be discussed in greater detail in the next publication of *Where Sun Meets Water* series.



**FIGURE 1.8.** Deployment ramp (top) and towing of FPV platform into exact location (bottom)



Source: © Lightsource BP Floating Solar Array, London.



Source: © Pixbee/EDP S.A.

## 1.4. Challenges

At this moment, FPV still comes with challenges that will require further research and learning to facilitate wider adoption.

### 1.4.1. Capital expenses

The capital costs of FPV are currently still slightly higher than or at best comparable to those of

ground-mounted PV, owing chiefly to the expenses for the floats, mooring and anchoring, and more stringent requirements for electrical components. The cost of floats is expected to drop over time, but economies of scale today remain constrained by a relatively small installed capacity.

Optimizing the floating platform design by reducing unnecessary buoyancy and cutting some mainte-

nance pathways (e.g., by employing dual-pitch structures) may also help to save some costs.

#### 1.4.2. Anchoring and mooring

Anchoring and mooring fixes a platform, and keeps PV panels correctly oriented toward the sun. The anchoring has to withstand wind load, waves, and potential currents. In some cases, the system needs to accommodate large fluctuations in water levels (e.g., in countries with dry and wet seasons). In some reservoirs, water depth and the terrain of the water body's bed can pose challenges to the installation and maintenance of the anchoring. Here, more complicated solutions may be required, adding to the cost of the project.

#### 1.4.3. Operation and maintenance

Operation and maintenance activities are generally more difficult to perform on water than on land. Boats are usually required to access PV arrays, even for installations with maintenance pathways. Anchoring and mooring cables must be regularly inspected, an activity that may require divers. Replacing parts is also more complex, and workers' safety must be adequately protected. While dust collection is less of an issue

on water than on land, FPV islands have been seen to attract birds (and their droppings) in the United Kingdom and Singapore. Protecting installations from birds is possible but would increase O&M expenses.

#### 1.4.4. Electrical safety and long-term reliability of system components

When electrical systems are constantly exposed to humidity and possibly also salinity (in offshore or near-shore installations), this poses risks to their operation, especially over the long run. Also, floating structures are in constant motion. Degradation and corrosion occur more quickly than on land, and bio-fouling is an additional challenge not faced by land systems. System components may need to be periodically reinforced or replaced to ensure systems' long-term reliability and safety.

Temperature fluctuations may cause floats to bloat and shrink, which can cause cracks. Freezing may stress system components, particularly joints. However, experience from the past few years (in Japan and China, among others) suggests that floating platforms can well survive ice and snow (figure 1.9).

**FIGURE 1.9.** Deployment of FPV in freezing conditions in Japan (left) and China (right)



Source: © Sungrow.



Source: © Sungrow.

**FIGURE 1.10. Stackable floats for efficient transport**



Source: © ISIGENERE.



Source: © ISIGENERE.

#### **1.4.5. Transportation of floats**

Most floats are bulky and have a very low weight-to-volume ratio, making them difficult to ship. The cost of transporting them to remote locations may be prohibitively high. The manufacturing of floats for many large FPV projects has been done locally to avoid this problem. In the future, mobile manufacturing equipment may offer a solution. Else, float suppliers try to collaborate with local plastic molding manufacturers to reduce cost of transport. Some suppliers are also designing

floats such that they can be more easily transported as illustrated in figure 1.10.

### **1.5. Comparison with ground-mounted systems**

As has been noted in this report, FPV installations offer several benefits over land-based systems, even as they pose additional challenges and costs. Table 1.2 provides a comprehensive look at both types of systems.

**TABLE 1.2. Floating and land-based photovoltaic systems: A comparison**

Parameter	Floating PV	Land-based PV
Land/water surface use	<ul style="list-style-type: none"> <li>• Does not compete for land with agricultural, industrial, or residential projects</li> <li>• Often easier to find sites near densely populated areas</li> <li>• Since water bodies often have a single owner, the permitting process is often less complicated</li> <li>• Expected lower leasing cost</li> <li>• Potential integration with aquaculture</li> <li>• May save water resources by reducing water evaporation</li> </ul>	<ul style="list-style-type: none"> <li>• Suitable/affordable land may be far away from load centers, thus requiring costly transmission infrastructure</li> <li>• Requires change in land use, which can be time consuming</li> <li>• Competes for land with city dwellings, industrial development, and agriculture</li> </ul>
Plant design	<ul style="list-style-type: none"> <li>• Modular design on flat surface</li> <li>• Limited tilt due to wind load considerations imply a lower energy yield in high-latitude regions</li> <li>• Anchoring cables require periodic inspection and maintenance</li> </ul>	<ul style="list-style-type: none"> <li>• Design must accommodate terrain and area constraints</li> <li>• Easier to implement tracking</li> <li>• Yield prediction is better established</li> </ul>
Performance/energy yield	<ul style="list-style-type: none"> <li>• Lower module temperatures (effect is dependent on climate)</li> <li>• Nearly no shading</li> <li>• Lower soiling from dust</li> <li>• Overall 5–10 percent higher initial performance ratio (climate specific)</li> <li>• Long-term degradation (e.g., potential induced degradation) is still uncertain</li> </ul>	<ul style="list-style-type: none"> <li>• Can benefit from tracking, bifacial, and optimum tilt angle</li> <li>• More temperature losses in hot climates</li> </ul>
Installation and deployment	<ul style="list-style-type: none"> <li>• In general, easy assembly, but highly variable depending on location and workforce availability</li> <li>• Transportation of floats to site is difficult; favors local production</li> <li>• Needs suitable launching area</li> </ul>	<ul style="list-style-type: none"> <li>• Efficiency varies depending on location and workforce availability</li> <li>• Needs heavy equipment and land preparation</li> <li>• Depends on soil quality</li> </ul>
Power system benefits	<ul style="list-style-type: none"> <li>• Synergy with existing electrical infrastructure</li> <li>• Possible hybrid operation with hydropower</li> </ul>	<ul style="list-style-type: none"> <li>• Costs of grid interconnection are often borne by project developer and can be prohibitively high</li> </ul>
Environmental	<ul style="list-style-type: none"> <li>• Long-term effects on water quality are not well established</li> <li>• Potential to reduce algae growth</li> <li>• Potential to reduce water evaporation</li> <li>• Potential impact on aquatic ecosystems</li> </ul>	<ul style="list-style-type: none"> <li>• Some adverse impacts during construction</li> <li>• Potential habitat loss or fragmentation</li> </ul>
Investment	<ul style="list-style-type: none"> <li>• Slightly higher costs on average due to floats, anchoring, mooring, and plant design</li> <li>• Cost of floats may drop as scale of deployment increases</li> <li>• Higher perceived risk due to lower level of maturity</li> </ul>	<ul style="list-style-type: none"> <li>• Huge installed capacity and hence very established investment and financing sector</li> <li>• Costs continue to drop</li> </ul>
Operation and maintenance	<ul style="list-style-type: none"> <li>• Harder to access and replace parts</li> <li>• Biofouling</li> <li>• Animal visits and bird droppings</li> <li>• Harder to maintain anchoring</li> <li>• Easy access to water for cleaning</li> <li>• Lower risk of theft/vandalism</li> </ul>	<ul style="list-style-type: none"> <li>• Easy to access</li> <li>• More affected by vegetation growth</li> <li>• Easier to deploy cleaning routines</li> </ul>

*continued*

**TABLE 1.2.** continued

<b>Parameter</b>	<b>Floating PV</b>	<b>Land-based PV</b>
<b>Durability</b>	<ul style="list-style-type: none"> <li>• Normally 5 to 10 years of warranty on floats</li> </ul>	<ul style="list-style-type: none"> <li>• Key system components durable for &gt;20 years</li> </ul>
<b>Safety</b>	<ul style="list-style-type: none"> <li>• Close to water, tend to have lower insulation resistance to ground</li> <li>• Constant movement poses challenge for equipment grounding</li> <li>• Risk of personnel falling into water</li> </ul>	<ul style="list-style-type: none"> <li>• Generally safe</li> </ul>
<b>Regulation and permits</b>	<ul style="list-style-type: none"> <li>• More difficult for natural lakes and easier for artificial ponds</li> <li>• Lack of specific regulations</li> </ul>	<ul style="list-style-type: none"> <li>• More established permitting process</li> <li>• Clearer regulations</li> </ul>
<b>Experience/level of maturity</b>	<ul style="list-style-type: none"> <li>• Cumulative capacity as of end of 2018: &gt;1.3 GWp</li> <li>• 4 years of experience with large-scale projects</li> </ul>	<ul style="list-style-type: none"> <li>• Cumulative capacity as of end of 2018: &gt;500 GWp</li> <li>• Thousands of projects built</li> <li>• 10–30 years of experience</li> </ul>

Source: SERIS.

Note: GWp = gigawatt-peak.



---

## References

- BNEF (Bloomberg New Energy Finance). 2017. "China's Renewables Curtailment and Coal Assets Risk Map." [https://data.bloomberglp.com/bnef/sites/14/2017/10/Chinas-Renewable-Curtailment-and-Coal-Assets-Risk-Map-FINAL\\_2.pdf](https://data.bloomberglp.com/bnef/sites/14/2017/10/Chinas-Renewable-Curtailment-and-Coal-Assets-Risk-Map-FINAL_2.pdf).
- . 2019. "Clean Energy Investment Exceeded \$300 Billion Once Again in 2018." <https://about.bnef.com/blog/clean-energy-investment-exceeded-300-billion-2018/>.
- Choi, Y.-K., N.-H. Lee, and K.-J. Kim. 2013. "Empirical Research on the Efficiency of Floating PV Systems Compared with Overland PV Systems." *CES-CUBE*. <https://www.semanticscholar.org/paper/Empirical-Research-on-the-efficiency-of-Floating-PV-Choi-Lee/a38910b49973d099603974c24cd55f43a8b0f64c>.
- Connor, P.M. 2009. Performance and prospects of a lightweight water-borne PV concentrator, including virtual storage via hydroelectric-dams. Proceedings of the ISES Solar World Congress 2009: Renewable Energy Shaping Our Future.
- Helfer, F., C. Lemckert, and H. Zhang. 2012. "Impacts of Climate Change on Temperature and Evaporation from a Large Reservoir in Australia." *Journal of Hydrology* 475: 365–78.
- IEA (International Energy Agency). 2018. *Renewables 2018*. OECD/IEA, Paris, France.
- IFC (International Finance Corporation). 2015. "Utility-Scale Solar Photovoltaic Power Plants: A Project Developer's Guide." Working paper, International Finance Corporation, Washington, DC. <https://openknowledge.worldbank.org/handle/10986/22797>.
- IRENA (International Renewable Energy Agency). 2018. "Renewable Power Generation Costs in 2017", International Renewable Energy Agency, Abu Dhabi. <https://www.irena.org/publications/2018/Jan/Renewable-power-generation-costs-in-2017>.
- Kenning, T. 2017. "India's SECI Invites Expression of Interest for 10GW of Floating Solar." PV Tech, December 19. <https://www.pv-tech.org/news/indias-seci-invites-expression-of-interest-for-10gw-of-floating-solar>.
- . 2018. "Maharashtra Discom Consults on 1GW of Floating PV, Retenders 1GW of Solar." PV Tech, April 11. <https://www.pv-tech.org/news/maharashtra-discom-consults-on-1gw-of-floating-pv-retenders-1gw-of-solar>.
- Le Nouvelliste. 2019. "Le projet de parc flottant sur le lac des Toules entrera en fonction cet automne." <https://www.lenouveliste.ch/articles/valais/martigny-region/le-projet-de-parc-solaire-flottant-sur-les-lac-des-toules-entrera-en-fonction-cet-automne-827633>.
- Liu, H., V. Krishna, J. L. Leung, T. Reindl, and L. Zhao. 2018. "Field Experience and Performance Analysis of Floating PV Technologies in the Tropics." *Progress in Photovoltaics: Research and Applications* 26 (12): 955–1012.
- Maisch, M. 2017. "40 MW Floating PV Plant in China Connected with Sungrow's Inverters." PV Magazine, May 19. <https://www.pv-magazine.com/2017/05/19/floating-pv-plant-in-china-connected-with-sungrows-inverters/>.
- National Energy Administration. 2018. "国家能源局新闻发布会介绍2017年度相关能源情况等 [National Energy Administration Press Conference on the Energy Situation for the Year 2017]." [http://www.nea.gov.cn/2018-01/24/c\\_136921015.htm](http://www.nea.gov.cn/2018-01/24/c_136921015.htm).
- Patil, S. S., M. M. Wagh, and N. N. Shinde. 2017. "A Review on Floating Solar Photovoltaic Power Plants." *International Journal of Scientific & Engineering Research* 8 (6).
- Planair and PITCO. 2017. *Assessment of Floating Solar PV Potential for Pakistan; Task 1: Commercial Readiness of FSPV—Global Market and Performance Analysis*. Unpublished report prepared for International Finance Corporation, Washington, DC.
- PV-Tech. 2017a. "Masdar and Indonesian Power Giant to Build World's Largest Floating Solar Plant." PV-Tech, November 28. <https://www.pv-tech.org/news/masdar-and-indonesian-power-giant-to-build-worlds-largest-floating-solar-pl>.
- . 2017b. "Sungrow Building Another Record 150MW Floating Solar Project in China." PV-Tech, June 1. <https://www.pv-tech.org/news/sungrow-building-another-record-150mw-floating-solar-project-in-china>.

- Qin, B., G. Zhu, G. Gao, Y. Zhang, W. Li, H. W. Paerl, and W. W. Carmichael. 2010. "A Drinking Water Crisis in Lake Taihu, China: Linkage to Climatic Variability and Lake Management." *Environmental Management* 45 (1): 105–12.
- Sahu, A., N. Yadav, and K. Sudhakar. 2016. "Floating Photovoltaic Power Plant: A Review." *Renewable and Sustainable Energy Reviews* 66 (Supplement C): 815–24.
- Santafé, M. R., P. S. F. Gisbert, F. J. S. Romero, J. B. T. Soler, J. J. F. Gozávez, and C. M. F. Gisbert. 2014. "Implementation of a Photovoltaic Floating Cover for Irrigation Reservoirs." *Journal of Cleaner Production* 66: 568–70.
- Saurabh. 2016. "Indian Hydro Power Company Plans 600 MW Floating Solar Power Project." Cleantechies, June 26. <http://cleantechies.com/2016/06/27/indian-hydro-power-company-plans-600-mw-floating-solar-power-project/>.
- Shiklomanov, Igor A. 1993. "World Fresh Water Resources." In *Water in Crisis*, edited by P. H. Gleick. Oxford: Oxford University Press.
- Sivakumar, B. 2019. "Tangedco aims for 250MW solar floating projects." The Economic Times, January 25. <https://energy.economictimes.indiatimes.com/news/renewable/tangedco-aims-for-250mw-solar-floating-projects/67682064>.
- Trapani, K., and M. Redón Santafé. 2015. "A Review of Floating Photovoltaic Installations: 2007–2013." *Progress in Photovoltaics: Research and Applications* 23 (4): 524–32.
- WEC (World Energy Council). 2013. "World Energy Resources: Solar." [https://www.worldenergy.org/wp-content/uploads/2013/10/WER\\_2013\\_8\\_Solar\\_revised.pdf](https://www.worldenergy.org/wp-content/uploads/2013/10/WER_2013_8_Solar_revised.pdf).
- World Bank Group, ESMAP and SERIS. 2019. "Where Sun Meets Water: Floating Solar Handbook for Practitioners." Forthcoming. Washington DC: World Bank.



# 2 TECHNOLOGY OVERVIEW

The electrical configuration of a floating PV (FPV) system is similar to that of a land-based PV system, except the PV arrays and often the inverters float on water. Figure 2.1 shows the typical configuration of a large-scale FPV power plant using a central inverter. Electricity generated by PV modules is gathered by combiner boxes and converted to AC power by inverters. The floating platform, together with its anchoring and mooring system, is an essential part of any FPV installation. In this chapter, we offer an overview of the components and technologies of FPV installations.

Section 2.1 describes mainstream FPV platforms and solutions, including anchoring and mooring. Novel

aspects of FPV systems are covered in section 2.2.<sup>2</sup> Section 2.3 deals with the operation of an FPV system in tandem with a hydropower station, a hybridization that opens a huge potential market, given the vast amount of hydropower installed capacity worldwide.

FPV systems can be installed on a wide variety of water bodies such as industrial ponds, hydropower reservoirs, agricultural ponds as well as other types of man-made water bodies like flood control reservoirs. All these applications are mainly inland freshwater bodies. However, FPV systems can also be built off-shore or near-shore. Figure 2.2 illustrates these various applications.

**FIGURE 2.1. Schematic of a typical large-scale FPV system, showing key components**

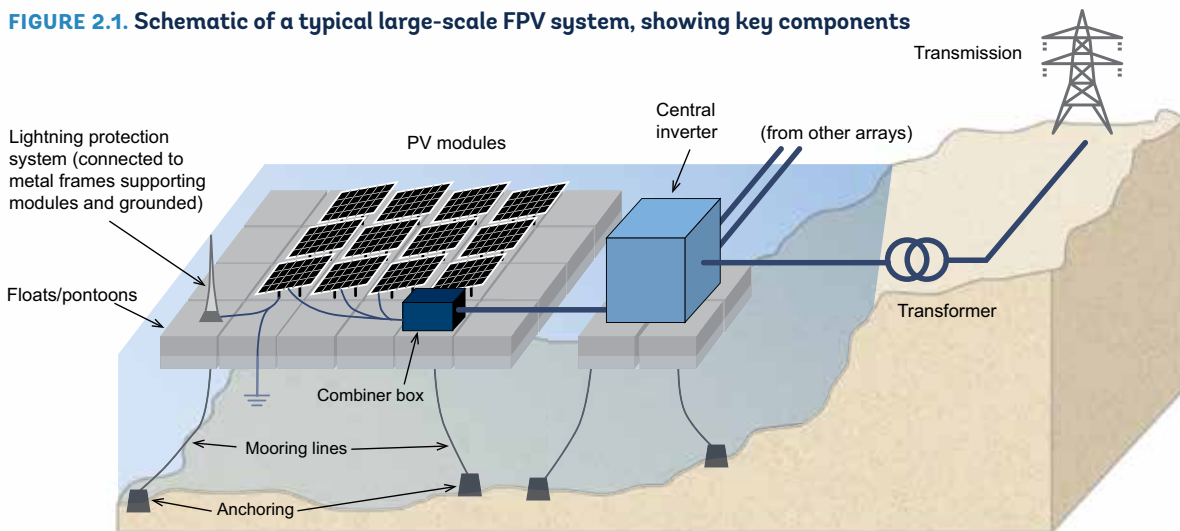

Source: SERIS.

2. Except in section 2.2, less commonly used technologies are not covered in this report.



**FIGURE 2.2. Typical FPV applications**

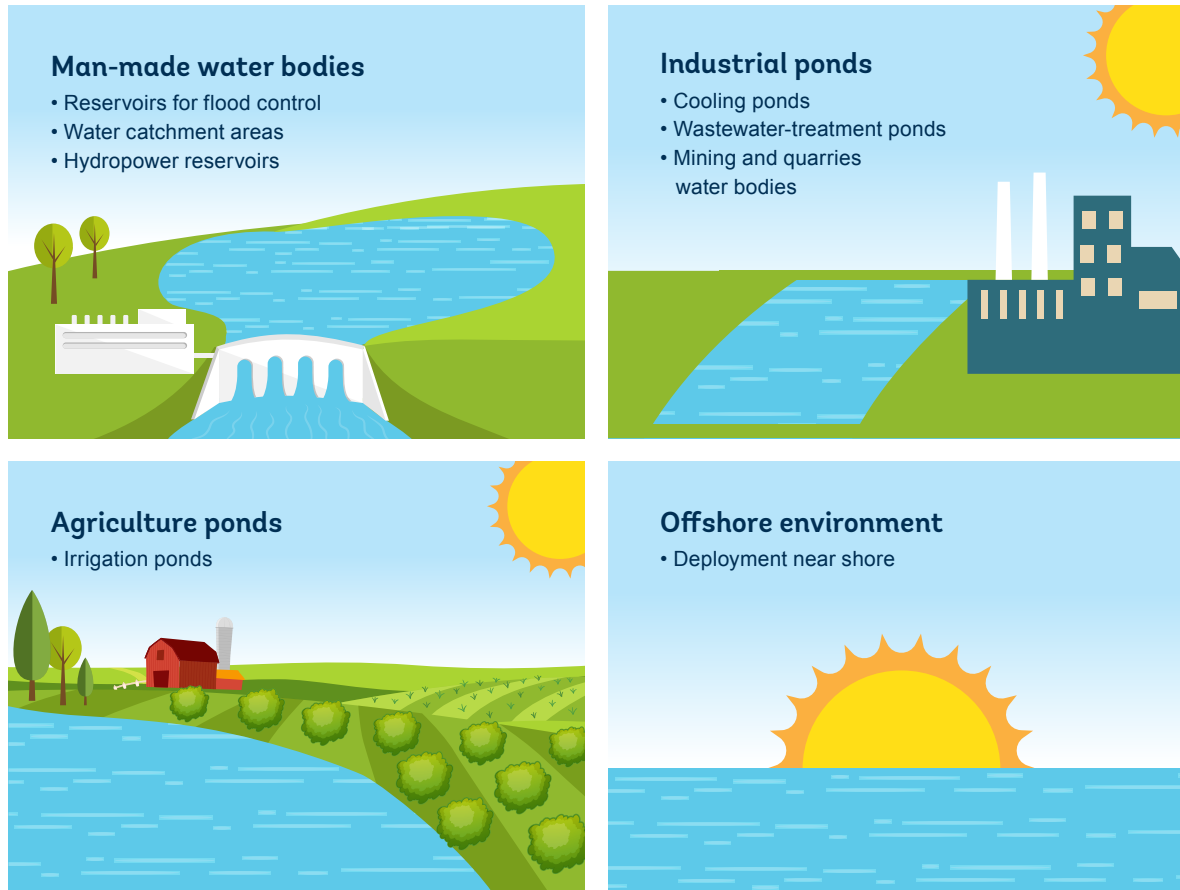

Source: Authors.

## 2.1. Key components and system designs

Most large-scale FPV plants have pontoon-type-floats, upon which PV panels are mounted at a fixed tilt angle. The floating structure can consist of floats alone (called pure floats), floats with metal trusses, or special membranes or mats. The platform is held in place by the anchoring and mooring system, the design of which depends on factors such as wind load, float type, water depth, and variation in water level. The layout of the PV plant is generally similar to that of land-based installations, except in the case of smaller floating plants located close to shore, which offer the option of placing the inverters on land, i.e., separated from the PV array. Both central and so-called string inverter configurations are possi-

ble. Details on the various technologies and designs currently available in the market are presented in the subsections that follow.

### 2.1.1. Floating platforms

#### *Pure-floats design*

Pure-float configurations use specially designed buoyant bodies to support PV panels directly. Table 2.1 summarizes the pros and cons of this platform type.

As an example, the Hydrelío floats from Ciel & Terre International are illustrated in figure 2.3. The float system is modular and consists of two types of floats. “Main floats” support the PV modules and provide an optimum tilt to the module (different tilt angles are possible, depending on the model used). “Secondary

**TABLE 2.1. Advantages and disadvantages of pure-float design**

Advantages	Disadvantages
<ul style="list-style-type: none"> <li>• Systems are easy to assemble and install</li> <li>• Systems can be scaled without major changes in design.</li> <li>• Few metal parts are required, minimizing corrosion.</li> <li>• Platform adapts to wave motion and relieves stress.</li> </ul>	<ul style="list-style-type: none"> <li>• Modules are mounted very close to water. This reduces air circulation and cooling effect from evaporation. It also generates a high-humidity environment for both PV modules and cables.</li> <li>• It is not cost-effective to transport pure floats over long distances, so they may need to be molded in nearby facilities</li> <li>• Constant movement may cause stress and fatigue to joints and connectors.</li> </ul>

Source: SERIS.

**FIGURE 2.3. Components of floats from Ciel & Terre International**

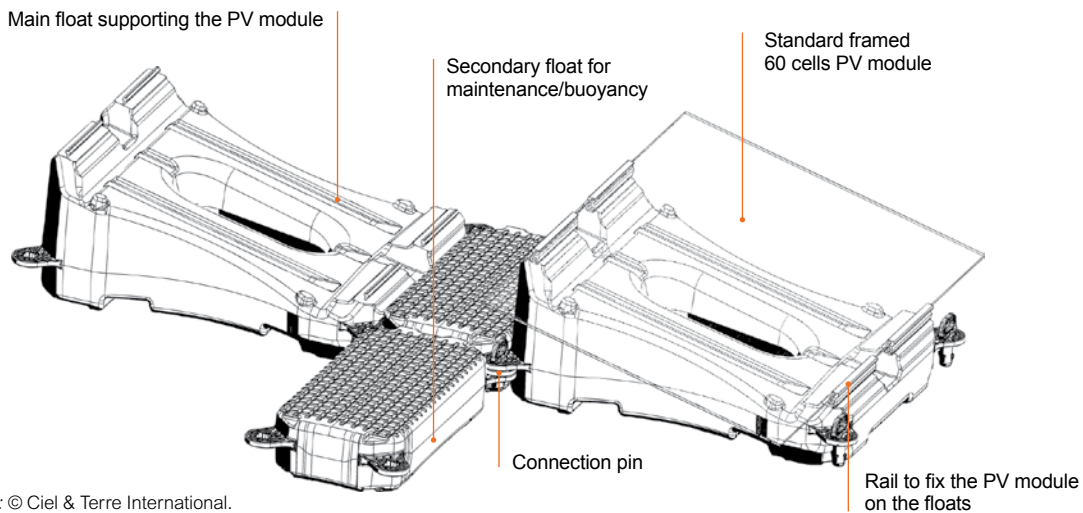

Source: © Ciel & Terre International.

floats” ensure connection with the main floats, provide sufficient spacing to limit the shading of PV modules, and are used as maintenance walkways while lending additional buoyancy. The floats are connected with pins or bolts to form a large platform. The material used is UV- and corrosion-resistant high-density polyethylene (HDPE) that is manufactured through a blow-molding process. It is compatible with drinking water.<sup>3</sup> This type of floating structure has established itself as the most common solution, with several suppliers in the market and an installed capacity worldwide of several hundred megawatt-peak (MWp).

3. To be compatible with drinking water, the material must pass certain standards. More details are provided in World Bank Group, ESMAP and SERIS, 2019.

Pure-float designs from other suppliers such as Sungrow Floating (Sungrow) are conceptually similar, with their own features. Figure 2.4 shows Sungrow’s floating platform design.

A further example, shown in figure 2.5, comes from Sumitomo Mitsui Construction Co., Ltd (SMCC). It features a more regularly shaped float for denser packing and easier transportation. Filled with polystyrene foam, the float will not sink even if damaged. In addition, the connecting parts are banded together, which, according to the manufacturer, reduces the risk of structural failure.

A last example, shown in figure 2.6, comes from ISIGENERE S.L. who developed the ISIFLOATING

**FIGURE 2.4. Sungrow floating platform design (top) and floats (bottom)**

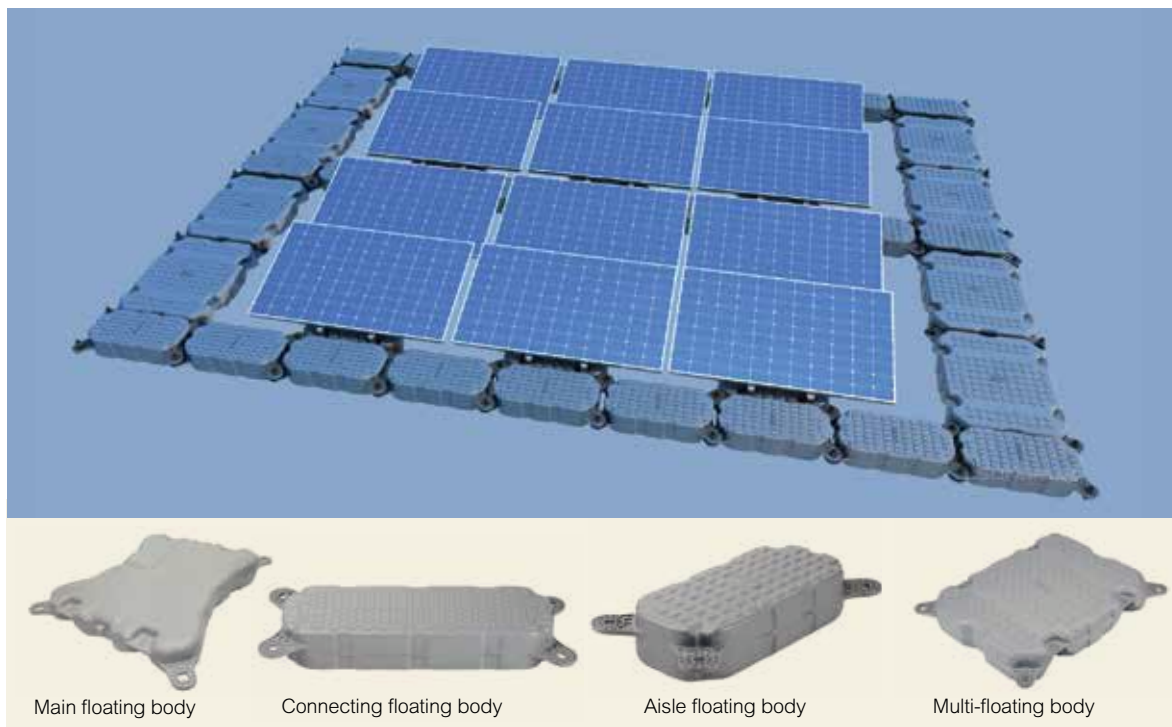

Source: © Sungrow.

**FIGURE 2.5. Illustration of Sumitomo's floating platform design**

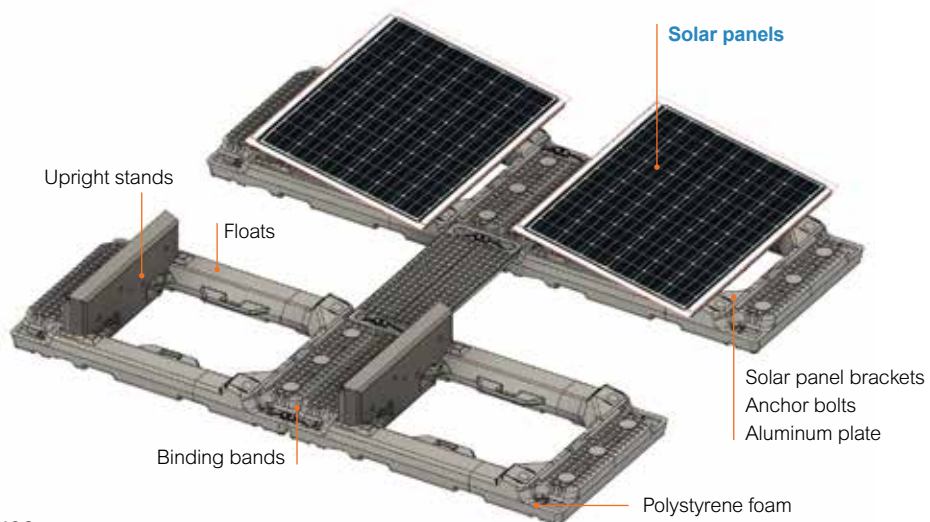

Source: © SMCC.

design, which was one of the pioneering floating solar systems since 2008. Their solution is characterized by using a HDPE pure bi-float design, which is compact, nestable and stackable (thereby easy to transport) and forms a closed volume when the PV panel is fixed on the top side.

***Pontoons + metal frames***

Another common design is to use metal structures (frames or trusses) to support PV panels as with land-based systems, but to affix the structures to pontoons, which serve only to provide buoyancy. In this case, there is no need for specially designed floats.

Often used are capped pipes having technical specifications similar to those of pure floats with respect to strength, non-toxicity, and durability. Pipes may be easier to obtain locally than pure floats. Such platforms are offered by companies such as 4C Solar and Koinè Multimedia (figure 2.7).

Alternatively, the metal trusses can be built on floats of other shapes, as in the examples from NRG Energia, Takiron Engineering and Scotra shown in figure 2.8.

In another design from Solaris Synergy, the metal frame stands on four specially designed floats (figure 2.9a).

**FIGURE 2.6. ISIFLOATING platform design**

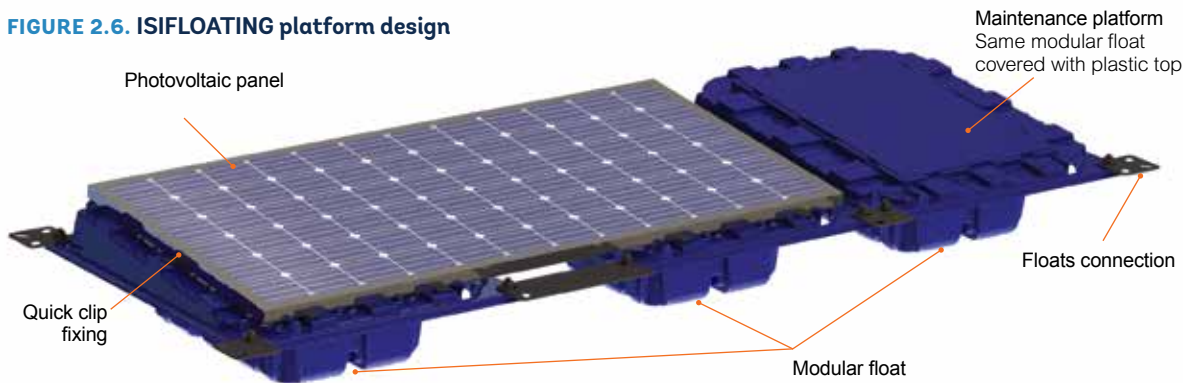

Source: © ISIGENERE.

**FIGURE 2.7. Various designs using metal frames and pipes to support PV panels, 4C Solar (top) and Koinè Multimedia (bottom)**



Source: © SERIS.



Source: © SERIS.



**FIGURE 2.8.** Various designs using floats and metal frames to support PV panels, NRG Energia (top), Takiron Engineering (middle), Scotra (bottom)



Source: © SERIS.



Source: © SERIS.



Source: © Scotra.



**FIGURE 2.9.** Solaris Synergy design: Floats (a), outer ring (b) and an illustration of automatic wind adaptation (c).



Source: © SERIS.

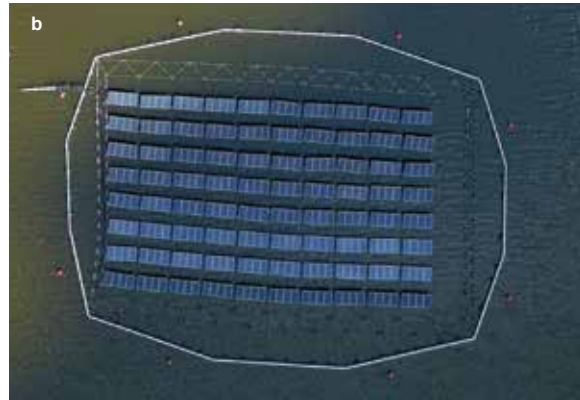

Source: © SERIS.

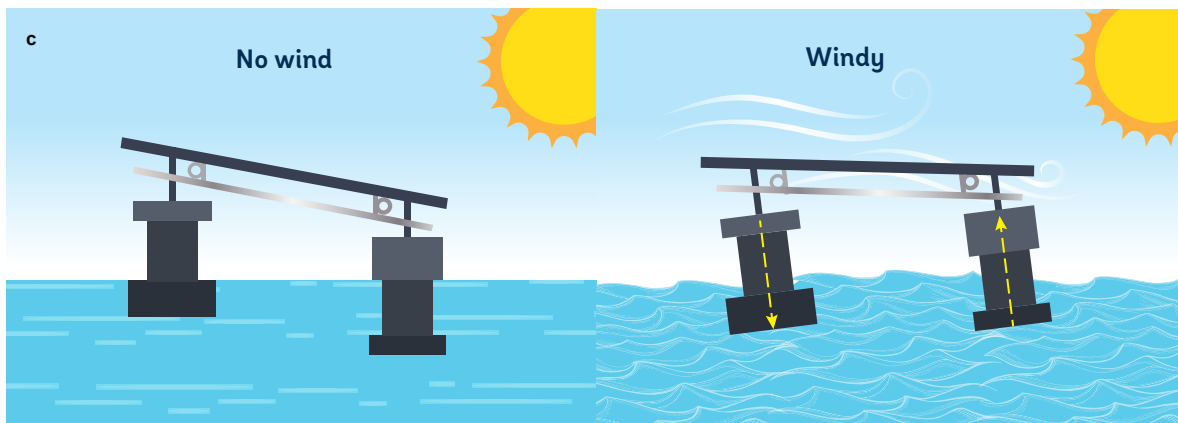

Source: Authors based on Solaris Synergy.

Each floating assembly supports several PV panels to form a unit. Multiple units are then held together by cables and encircled by an outer ring, as shown in figure 2.9b. Within a single ring, a maximum of 2MWp can be installed; rings can be connected in a honeycomb pattern to achieve any desired total capacity. One interesting feature of this design is that panels can auto-adapt to reduce wind load, because wind produces torque that flattens the tilt of PV panels, which subsequently relieves the drag forces produced by wind (figure 2.9c).

The chief advantages and disadvantages of this type of platforms are listed in table 2.3.

#### **Membranes and mats**

Another type of platform is created by simply covering the entire water surface with rubber mats to create a base for PV installation (figure 2.10). Although much less common than the previous two types of platforms, this option is being explored by Continental Corporation and other companies. Covering the entire water surface is particularly suitable for desert areas (e.g., parts of Israel) to prevent evaporation losses and save scarce water for irrigation or drinking. The design is conceptually simple and provides an easy base for installation and maintenance. In figure 2.10, the membrane is fastened to a circular concrete rim and equipped with weights and floats to preserve its shape and to form trenches of varying depth that

**TABLE 2.3. Advantages and disadvantages of pontoon + metal structures.**

Advantages	Disadvantages
<ul style="list-style-type: none"> <li>• The concept is simple.</li> <li>• Floats are easy to make and therefore can be easily sourced locally.</li> <li>• Wave movement between PV modules is less variable, thus reducing wear and tear on module connection components and wires.</li> </ul>	<ul style="list-style-type: none"> <li>• With more rigid structures, waves cause stress to concentrate at certain points.</li> <li>• Structures are more difficult to assemble.</li> <li>• Access for maintenance can be difficult in certain designs.</li> </ul>

Source: SERIS.

**FIGURE 2.10. Floating solar membrane cover concept (left) and installation (right)**



Source: © Continental Corporation.



Source: © Continental Corporation.

accommodate changes in water level and hold rain-water. This technology may not be easily scalable. At the moment, it is more suitable for smaller-scale systems on reservoirs or irrigation ponds up to around 100,000 to 200,000 m<sup>2</sup> in size.

Similarly, Ocean Sun uses large, round membranes fixed to a floating ring up to 72 meters in diameter. The system was adopted from fish farming in Norway and was initially used for offshore applications (and thus is discussed in section 2.2.5) but is starting to be also deployed on inland reservoirs.

Membrane-based systems have the advantage of being in direct contact with water; heat from sunlight is discharged into the water, thus lowering the operating temperature of the PV modules and increasing energy yield.

It is also possible to float specially designed PV panels directly on water or in a semi-submerged manner. However, so-called submerged FPV (discussed further in section 2.2.3) is not yet a mainstream solution and is not widely deployed.

### 2.1.2. Anchoring and mooring systems

An appropriate anchoring and mooring system is a critical part of an FPV plant. There are three basic ways to hold a floating platform in place: bank anchoring, bottom anchoring, or piles (figure 2.11). Developers choose the design that best suits the platform location, bathymetry (water profile and depth), soil conditions, and variation in water level. More information on how to choose and design an anchoring and mooring system is provided in the next publication of *Where Sun Meets Water* series (World Bank Group, ESMAP and SERIS, 2019).

#### *Bottom anchoring*

Bottom anchoring is used in the vast majority of existing FPV plants. The anchor must keep the FPV arrays in place for 25 years or more, unlike the kedge anchors used on ships, which need only resist lateral movement over a limited period of time. Many mature anchoring solutions exist in marine and ocean engineering, as well as in watercraft industries, solutions that can be easily transferred and adapted to the FPV context.

**FIGURE 2.11. Schematics of bottom anchoring (here using so-called concrete sinkers), bank anchoring, and anchoring on piles**

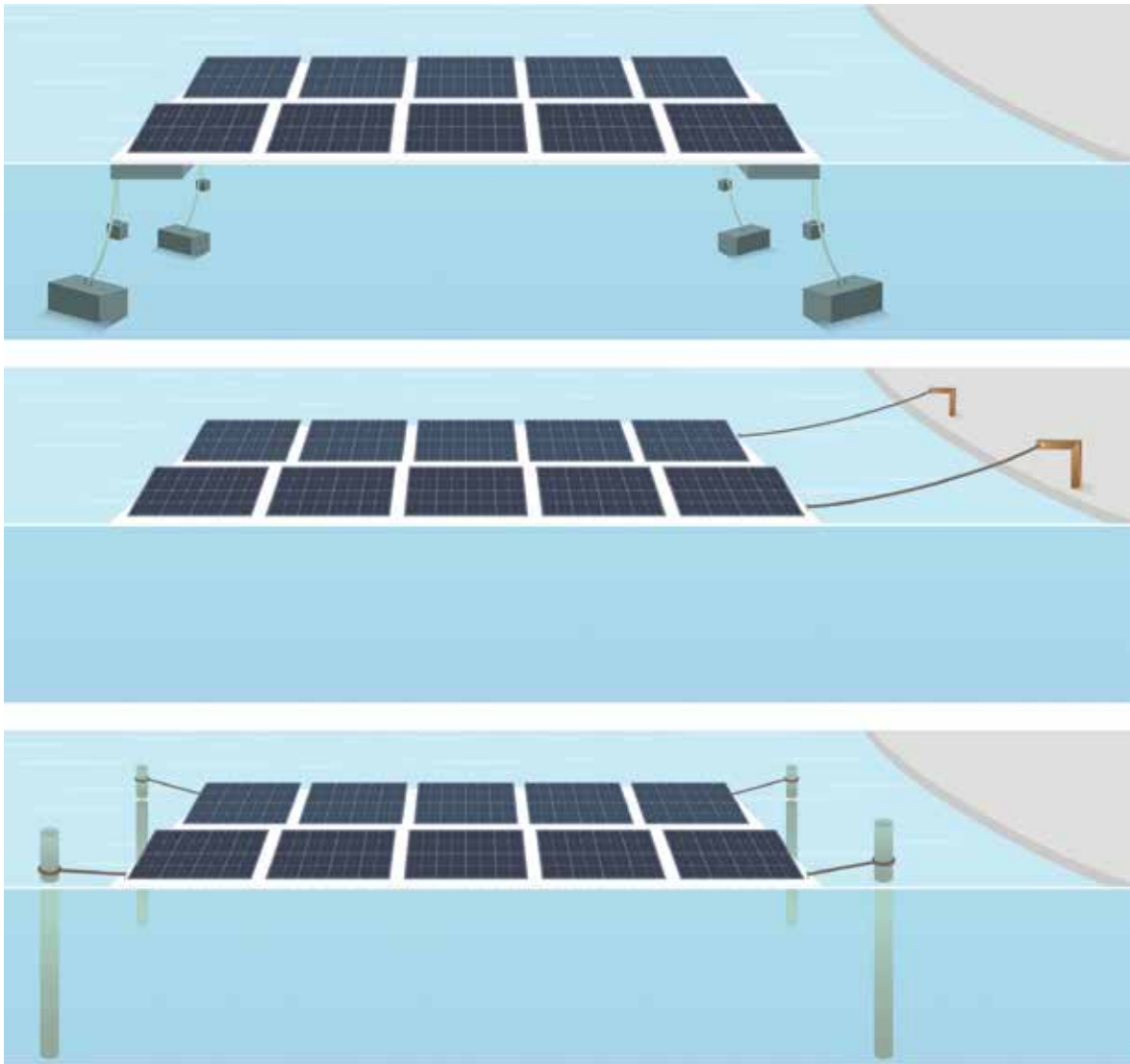

Source: Authors.

There are two broad types of permanent bottom anchors—self-seating anchors and installed anchors. One self-seating anchor commonly used for FPV consists of a dead weight, usually a large concrete block (called a “concrete sinker”) that resists movement by its sheer weight and, to a lesser degree, by settling into the substrate. This cheap and simple option is effective in many cases. Other common types of self-seating anchor include mushroom anchors and pyramid anchors.

Where the terrain and soil conditions are more complex, or where loads are large, installed anchors may be needed to provide a stronger hold to the bottom. A helical anchor is a shaft equipped with wide spiral blades that allow it to be screwed into the substrate. Installed anchors are generally more expensive than the self-seating variety; specialized boats and divers are often required.

With any anchor, mooring lines must be selected and deployed. Enough slack should be present to accommodate stress levels and variations in water level, but not so much as to permit excessive movement of the platforms. More details about anchoring and mooring are offered in World Bank Group, ESMAP and SERIS, 2019.

### **Bank anchoring**

Bank anchoring is particularly suitable for small, shallow ponds, where the FPV plant is close to shore (figure 2.12). Bank anchoring may also be used when other options are not available—for example, when the bottom of the basin is lined with plastic and cannot accommodate an anchor.

Whenever possible, bank anchoring should be considered, as it is often the most cost-effective option. It allows easy access to anchoring points, both for deployment and for periodical inspection during O&M. But feasibility of bank anchoring may also depend on shore conditions and on permission from the pond owner.

### **Piles**

For some (typically shallow) water bodies, it may be possible to drill or ram piles into the basin floor. The float platform is then moored to the piles. This con-

**FIGURE 2.12. Bank anchoring example**



Source: © ISIGENERE.

figuration is particularly useful for installations with special features such as tracking and concentration (see section 2.2.1). In this case, the pile provides a central pole around which the platform revolves. In response to variations in water level, the platform can (in principle) slide up and down the piles. However, pile drilling usually involves specialized equipment and civil works; hence it is much more costly than anchoring.

### **2.1.3. Electrical configuration (central vs. string inverters)**

Like ground-mounted PV plants, FPVs use either central inverters or string inverters for their electrical layout. For large FPV plants, it is beneficial to install the inverters on water instead of on shore so as to avoid excessive resistive losses. Special floats made of stainless steel or concrete are used to support containerized central inverters. Depending on the supplier, the inverters may be integrated with transformers, with medium-voltage cables connecting the transformers to the transmission grid. This is the configuration used by Sungrow at its large FPV farms in China (figure 2.13).

For use on water, some engineers advocate string inverters. They are lighter than large central inverters and can be placed on regular floats (figure 2.14). Although string inverter solutions tend to be more expensive than central inverters in large FPV plants, they offer higher granularity, so that in the event of a failure only small sections of the PV plant are affected. The failed inverter can be quickly switched out if a few replacement units are kept on site. In FPV plants, easy access to the string inverters should be part of the layout. For example, rather than being placed in the center of a large array, the inverters ought to be on the periphery, accessible by boat.



**FIGURE 2.13.** Sungrow FPV farm with a central inverter on a floating island (left), detailed view of the floating island for the central inverter (right)



Source: © Sungrow.



Source: © Sungrow.

## 2.2. Novel FPV concepts

FPV plant designs are not limited to the standard components or options discussed above. In this section, we describe some additional features that could be implemented in FPV installations. These include tracking, concentration, and active cooling, all of which are still in an early stage of development. Most pilot plants are small in scale, and have been deployed for research and testing purposes.

### 2.2.1. Tracking

Tracking can be achieved by rotating the entire floating platform to follow the sun from east to west. This type of vertical-axis azimuth tracking is particularly relevant for FPV, since it is relatively simple to move an array on water (with its lower resistance) than on land. In addition, because alignment with the sun's position need not be completely accurate, the disturbances caused by wave movements are of minor consequence. Platforms can be moored around a central pile or surrounded by a fixed outer ring (or polygon), as illustrated in figure 2.15. The platform is usually circular, with a diameter of up to 100 meters. The platform is rotated by motors. Some engineers have proposed the use of bow thrusters to complete the rotating motion. Pilot tracking systems have been installed at the Lotus project in Suvereto, Italy, and in

**FIGURE 2.14.** String inverters placed on the floats together with PV arrays



Source: © SERIS.

**FIGURE 2.15.** Illustration of azimuth tracking for an entire platform around a central pile

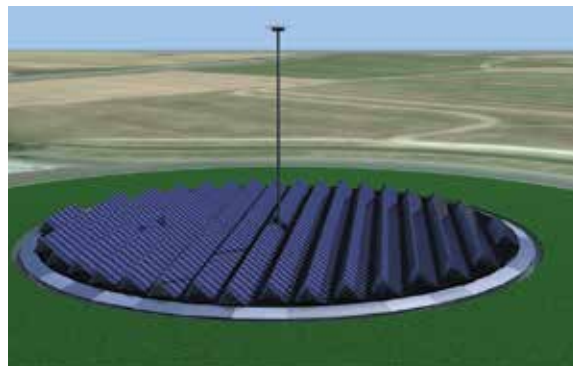

Source: © Koine Multimedia.

**FIGURE 2.16.** The 100 kW tracking FPV plant at Hapcheon Dam, Korea



Source: © K-Water.



Source: © K-Water.

Navacchio, Pisa, also in Italy (Patil Sujay, Wagh, and Shinde 2017; Rosa-Clot and Tina 2018a). A larger plant of 100 kilowatt (kW) capacity, installed at Hapcheon Dam in the Republic of Korea, consists of four rotating structures (figure 2.16). A few tracking FPV systems have been deployed in combination with concentration (see section 2.2.2).

Cost is the biggest challenge for tracking systems. Both the initial capital investment and the maintenance costs are rather high. In addition, the platform size is limited, so scaling up is more challenging. In general, single-axis trackers improve the energy output of a solar farm by about 20 to 30 percent (Mousazadeh and others 2009). The gain is less for azimuth tracking in low-latitude regions, since the sun position is at high angles at midday. Moreover, to reduce wind loads, FPV systems are typically installed at a maximum tilt angle of 10–15 degrees, which might further reduce the effect of azimuth tracking. In these cases, horizontal tracking is needed. This may be more difficult to realize for FPV systems, but novel tracking mechanisms are being explored in this area.

### 2.2.2. Concentrated FPV

Concentrated PV could be a relevant and attractive option on water, since the ambient temperature tends to be lower and water, as a coolant, is readily available. Both help to alleviate the common problem in concentrated PV systems of high operating tempera-

tures. On water, high concentration is not possible because constant movement of the platforms impede precise position control. However, a certain degree of concentration can be achieved using mirrors or Fresnel lenses. For example, light can be concentrated to a horizontal PV panel using V-shaped mirrors (Rosa-Clot and Tina 2018b; Tina, Rosa-Clot, and Rosa-Clot 2011), as illustrated in figure 2.17. Calculations show that the concentration factor can be as great as three.

Concentration in FPV systems pairs naturally with tracking, as indicated by the so-called floating tracking cooling concentrator system. Here, mirrors are placed in front of each PV panel, and the entire platform rotates in a circle to track the sun using azimuth tracking, as described in the previous section. One such system was built in Australia (figure 2.18).

In principle, dual-axis tracking is also possible. A system in India has implemented dual-axis tracking on water at a very small scale, as shown in figure 2.19. This technology, called the Liquid Solar Array, uses plastic concentrators that float on water and are mounted on anchored rafts. A thin focusing Fresnel lens rotates to track the sun. Silicon PV cells are housed in a PV container that floats on water where the cells are cooled thanks to the surrounding water, while allowing the concentrated light to enter through a glass window. In bad weather the lens is protected by rotating under the water surface to avoid damage in high winds. Water therefore becomes an essential

**FIGURE 2.17.** Low concentration with V-shaped mirrors for FPV



Source: © Koine Multimedia.



Source: Authors based on Rosa-Clot and Tina 2018b.

**FIGURE 2.18.** FPV with azimuth tracking (1-axis, vertical) in a wastewater facility, Jamestown, Australia



Source: © Infratech Industries.

component of the design, both for cooling and protecting (Connor 2009).

As with general FPV tracking systems, concentration systems suffer from the drawbacks of high cost and less scalability owing to the large number of accessory components and structures.

### 2.2.3. Submerged FPV

Putting PV panels in direct contact with water to exploit its cooling properties can significantly lower operating temperature, thereby increasing power output. This is a major benefit of the membrane-based FPV systems described earlier, but it also accounts for the appeal of submerging PV modules just beneath



**FIGURE 2.19.** Sunengy's Liquid Solar Array with dual-axis tracking and concentrators (left), detail of the collector with lens concentrator (right), Whalvan Hydroelectric Dam, Lonavala, Maharashtra, India



Source: © Sunengy.



Source: © Sunengy.

the water's surface or floating flexible modules directly on top of the water's surface (figure 2.20). Aside from lower module temperatures, submerged FPV systems offer the advantage of reducing mechanical load, especially from wind or currents, as well as internal stress from wave motions, thus simplifying mooring. Buoyancy for thin, flexible films (made of crystalline silicon or other thin-film materials) can be supplied largely by the PV panels themselves, which typically are laminated with materials that encapsulate air while resisting moisture. They can be installed easily from large rolls, which are also easy to transport to the site. The total material usage for deploying self-buoyant PV modules is dramatically less than for conventional PV panels.

Submerged FPV has been explored and discussed by several authors (Rosa-Clot and Tina 2018c; Trapani and Millar 2014; Trapani and Redón Santafé 2015). The first test system, with a 0.57 kilowatt-peak (kWp) capacity, was deployed in 2010 in Sudbury, Canada, by MIRARCO Mining Innovation (Trapani and Redón Santafé 2015), shown in figure 2.21. Since then, several companies have tested systems using floating thin films.

Submerged FPV still has a long way to go to prove its industrial relevance. Among the challenges to be overcome are those related to long-term reliability and electrical safety. The electrical components are often in contact with water, so they must be able to resist moisture and corrosion. Another problem is adhesion or accumulation of dirt or sediment on the panel surface, especially in the case of semi-submerged thin-film panels. When water dries in the sun, dirt can be left on the surface of flat-lying panels. Bio-fouling is another potential concern. Perhaps most importantly, the actual performance gains of submerged FPV have yet to be demonstrated.

#### **2.2.4. Active cooling**

Some float suppliers also integrate pumping systems into the floating platform to spray water onto the PV modules to cool them (figure 2.22). Sprinklers are triggered when the module temperature (as detected by sensors) reaches a certain threshold. After spraying, the module temperature drops quickly, improving performance.

This solution seems quite natural and sensible for FPV, since water is readily available. In hot climates, this can indeed reduce temperature-related reductions in power output, which is a major loss factor. However, since the pumping also consumes energy, the

**FIGURE 2.20.** Semi-submerged floating thin-film module and the forces to which it is exposed

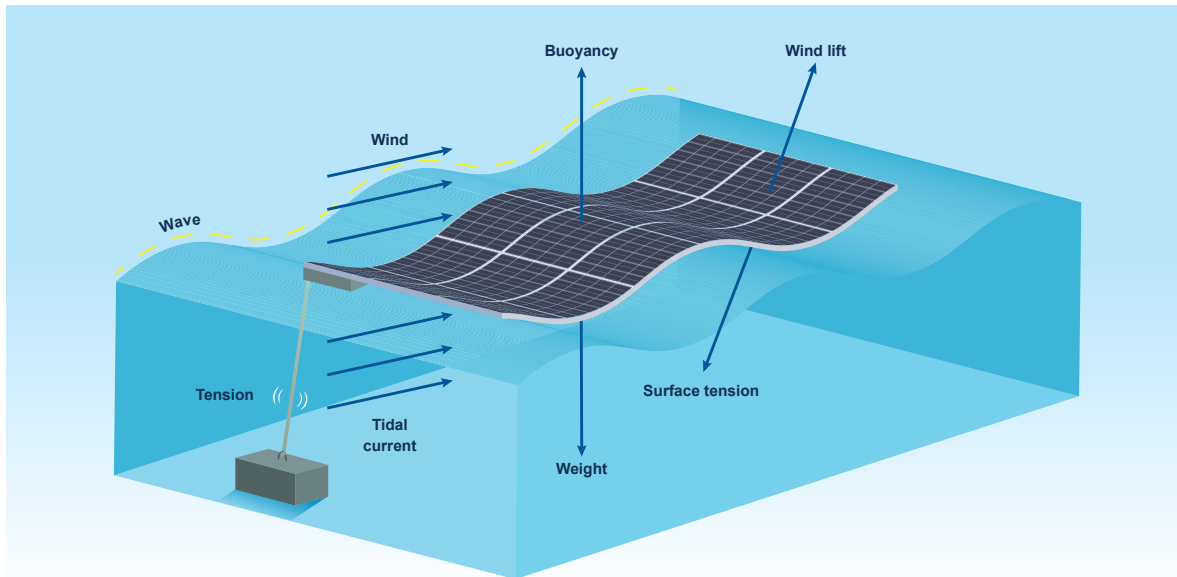

Source: Authors based on Trapani and Redón Santafé 2015.

**FIGURE 2.21.** The 0.57 kWp MIRARCO Mining Innovation semi-submerged floating thin-film system in Sudbury, Canada



Source: © MIRARCO Mining Innovation.



operation algorithm needs to be carefully optimized to ensure a net energy gain. In addition, the improved performance must be large enough to make the investment worthwhile. Another problem, depending on the water quality of the reservoir, is that soiling may occur over repeated cycles of spraying and drying. Currently, active cooling has been employed for only a few FPV systems, and no rigorous assessment of its overall benefit is yet available.

### 2.2.5. Offshore/near-shore FPV

Offshore or near-shore FPV is conceptually similar to FPV on inland water bodies. However, offshore or near-shore environments present some additional challenges and difficulties:

- Water surface conditions are much rougher because waves and winds are higher.
- Mooring and anchoring becomes even more critical due to tidal movements and currents.
- The salinity of seawater is tougher on components.
- Bio-fouling is much more likely.

The more stringent requirements for floats, anchors, and components imposed by the harsher environment

may necessitate a different platform design or the use of different technologies. However, the rich experience of marine and offshore industries should make it possible to meet the challenges. Compared to the open sea, areas such as lagoons and bays are relatively calm—and thus more suitable for FPV installations. There are many such areas along the world’s coastlines, offering a large potential market for FPV. Moreover, offshore or near-shore FPV may be the only way for small islands such as the Maldives to “go green” without having to clear scarce land to make room for ground-mounted PV installations.

Several companies are researching offshore and near-shore FPV solutions. Austria’s Swimsol has launched a pilot plant in the Maldives (figure 2.23). Its system consists of 25 kWp modular platforms, each supported by floating buoys and moored by helical anchors. According to Swimsol, the platform can withstand waves two meters high and winds of 120 km/h.

For its offshore FPV platforms, Norway’s Ocean Sun borrows the floating technology from offshore fishing farms, as shown in figure 2.24, using round floaters that can stretch a membrane over diameters up to 72 meters. The membranes, which are in permanent

**FIGURE 2.22. Active cooling solution**



Source: © Ciel & Terre International.

**FIGURE 2.23.** Swimsol’s pilot offshore FPV plant on a resort island in the Maldives



Source: © Swimsol.

**FIGURE 2.24.** Ocean Sun’s offshore floating platform in Norway, with membrane to hold PV panels



Source: © Ocean Sun.

contact with water, provide good thermal conduction of heat from the PV panels, effectively reducing the operating temperature of the modules. In addition, the membranes are strong enough to walk on (for installation and maintenance) while also being flexible enough to accommodate waves.

Offshore or near-shore FPV is still in a nascent stage, and practical experience is limited. The biggest uncertainties are long-term reliability and costs. In general, marine grade materials and electrical components are needed, and the structural design must withstand extreme weather. It is likely that PV modules, as well, would have to be reinforced for offshore conditions.

Operation and maintenance costs may also be higher than for inland FPV installations.

### 2.3. Hybrid operation with hydropower plants

PV power generation is inherently variable owing to cloud cover and the diurnal cycle. Research is being conducted to reduce ramping rates and smooth the output from PV systems using energy storage systems or other solutions. However, while the cost of utility-scale energy storage systems is dropping, it remains high. Maintenance and disposal of the storage system after its shelf life also needs to be considered. One storage solution in common use today is pumped-storage hydropower, in which reservoirs are used as a storage system. When energy demand is low (e.g., overnight), water is pumped from a downstream reservoir into an upstream reservoir behind a hydroelectric dam and then released through the dam to generate electricity at times of peak demand.

In the same spirit, the rise of FPV offers a new and promising alternative: combining FPV with hydropower stations. Being a kind of instantly adjustable energy source, hydropower has the potential to become a real-time compensator for variable PV power. The reservoirs behind hydroelectric dams can store water during periods of high irradiance and release it at cloudier times or when demand spikes and it therefore serves as a storage system of the hybrid solar and hydropower operation.

Apart from utilizing the reservoir surface, the combination also allows easy grid connection through the infrastructure of the hydropower plant. This option is best conceived as a way to maximize the utility of existing hydropower stations rather than as a way to justify the building of new dams. Where rainfall patterns are highly seasonal, as in monsoon areas, there is an additional advantage of complementarity over the course of the year: More solar power is generated during the dry season (when water levels and hydropower output are low); the reverse is true for the rainy season.

Establishing synergy between hydroelectric dams and FPV plants to generate more electricity is becoming an attractive option for the operators of existing hydropower plants. In every case, total output from the hybrid system must meet grid dispatch demand. This can be achieved through the following adjustments:

- Electricity generated by the PV system is transmitted to the hydropower substation. The PV system is treated as a nondispatchable virtual unit of the hydropower plant. From the perspective of the power grid, the hybrid system constitutes a single dispatchable source of power, analogous to a conventional power plant (An and others 2015; Fang and others 2017; Gebretsadik 2016).
- The automatic generation control (AGC) system of the hybrid system monitors the real-time output power from the PV source, receives set points from the grid-dispatch center, and calculates the total power set point for hydropower (Gong and others 2014). The AGC then determines the active power set points for each hydro unit.
- In the short term, the hydropower plant can counter-adjust its output through a small movement of guide vanes, smoothing the variable output curve of the FPV system (An and others 2015).
- In daily operation, the hydropower plant can adjust the water level in the reservoir to compensate for the randomness of PV output. At times of high PV output and low system demand, the hydropower units can reduce their output and store water in the reservoir. At times of low PV output and high system demand, the hydropower plant releases water and increases its output. To meet the water requirements of other reservoir functions—such as irrigation, downstream environmental flows, and flood control—the daily water balance of the reservoir should be maintained at its level before the installation of the hybrid system.
- During the rainy season, when water run-off is high, hydropower plants with limited reservoir capacity must operate at maximum output, and therefore will not be able to compensate for PV variations. Hybrid



operation will be ineffective under such conditions. Water will have to be spilled or PV power curtailed.

Hybrid hydropower and FPV systems can offer great advantages in terms of grid integration, equipment utilization, and cost:

- Hybridization with hydropower improves the quality of PV power. As variable, nondispatchable PV power is at least partly converted to stable and dispatchable electricity, the consumption of PV power rises, as do the profits of the developer of the PV power plant. From the point of view of the power system, stable and dispatchable PV power means lower requirements for spinning reserves and energy storage, thus reducing the overall operational cost of the power system (An and others 2015). Another great advantage of hybrid operation is the benefit of making maximal use of existing electrical infrastructure, including high voltage grid access and transformers, which can lower capital costs and accelerate project implementation.
- Water resources and solar energy can compensate for each other when operated together as a hybrid. This is true not only over the diurnal cycle

(using solar energy during the day and hydropower at night), but also across the seasons. During the dry season, for example, when there is low water storage and low hydropower output, the bright, sunny weather allows for higher PV generation. PV thus makes up for the hydropower deficiency. Supported by the PV output, hydropower can dispatch electricity in a more flexible manner.

- Deploying PV systems on reservoir surfaces can save on the cost of land. The existing road access to the hydropower plant likely reduces construction and transportation costs, as well.

The development of grid-connected hybrid hydropower and FPV projects is still in the early stages. A small FPV system of 220 kWp has been deployed on a hydropower dam in Portugal. Many other such projects, some large in scale, are being discussed or are under development.

Currently, the world's largest hybrid hydropower and solar PV project is one where the PV component is ground-mounted. The Longyangxia hydro/PV power plant project in Qinghai, China, is striking in its size and hence is a role model for such conjoint operation (Qi 2014; Zhang and Yang 2015).

**FIGURE 2.25.** Satellite image of Longyangxia hybrid hydro/PV power plant



Source: © Google Earth.

The Longyangxia hydropower plant was commissioned in 1989 with four 320MW Francis turbine-generator sets that generate 5.942 GWh of electricity each year. The plant serves as the major load-peak-ing and frequency-regulation power plant on Chi-na’s northwest power grid. The dam is located at the entrance of the Longyangxia canyon on the Yellow River in Gonghe County, Qinghai Province. It provides carryover storage and excellent multi-year regulation capability. The designed normal storage water level is 2,600 meters; the dead water level, 2,530 meters; the regulating storage,  $193.5 \times 10^8$  cubic meters.

The associated Gonghe solar plant is located 30 kilo-meters from the Longyangxia hydropower plant (figure

2.25). The first phase was built and commissioned in 2013 with a nameplate capacity of 320 MWp and aver-age annual energy generation of 0.498 GWh. An addi-tional 530 MWp (Phase II) was completed in 2015. It is one of the largest solar PV installations in the world.

The PV power plant is directly connected to the reserved line inside the Longyangxia hydropower substation by a 330 kV transmission line.

The hybrid system is operated in a complementary manner (Zhang and Yang 2015). Figure 2.26 com-pares the total system output and the hydro output before and after hybrid in a relatively dry year (Qi 2014). After the PV plant was added, the grid opera-

**FIGURE 2.26. Before and after hybridization operation on a day in December in a dry year: hydropower output (top) and total system output (bottom).**

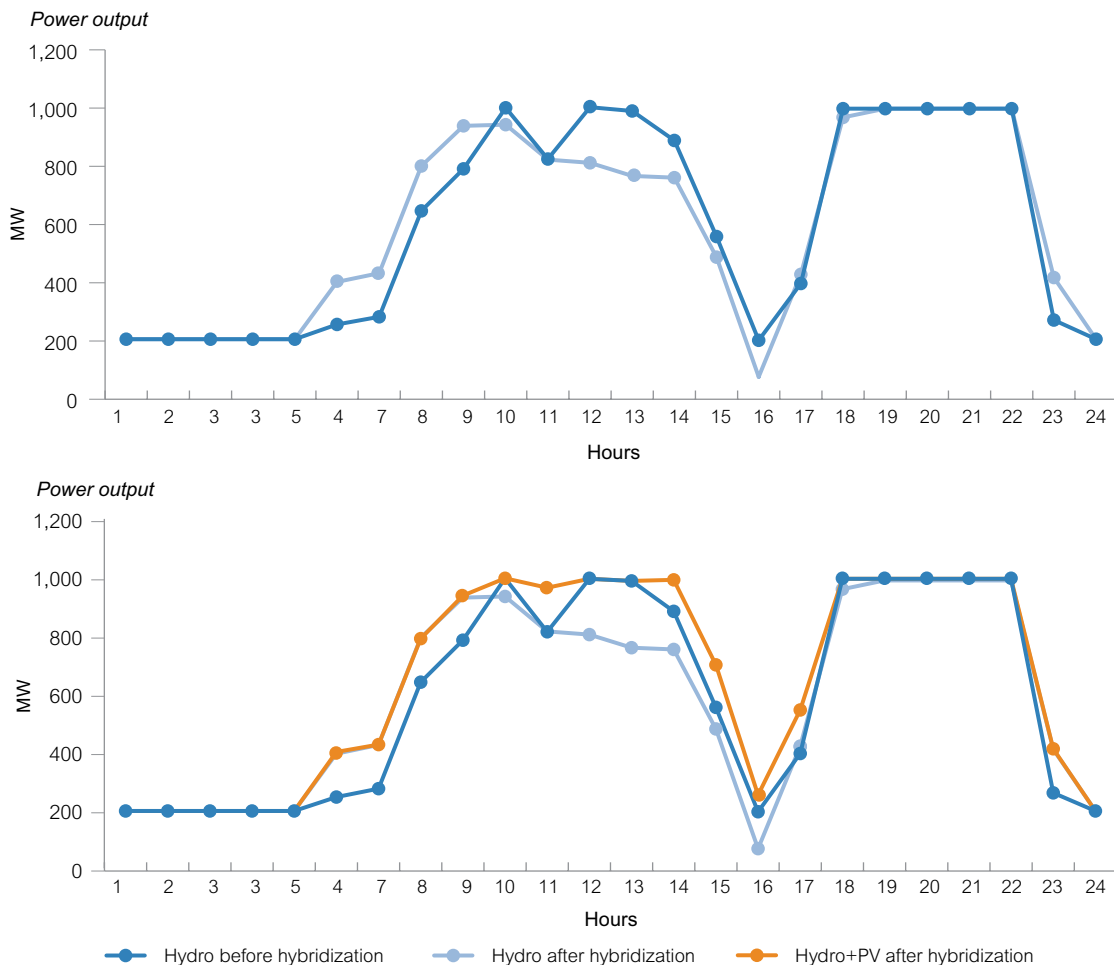

Source: SERIS based on Qi 2014.



tor began to issue a higher power dispatch set point during daylight hours. The increased portion is shown in the right side of the figure. Despite this, output from the hydro facility is lower than it was before the PV plant came on stream, especially from 11 am to 4 pm, when PV generation is highest. The saved energy is then used during the early morning and late-night hours. Although the daily generation pattern of the hydropower plant has changed, the daily water balance in the reservoir has been kept as it was in order to meet the water requirements of other downstream

reservoirs. All power generated by the hybrid system is absorbed by the grid without curtailment.

The hybrid operation closely follows power dispatch set point on sunny days. On cloudy days the hybrid operation compensates the variability of solar output by using flexibility of hydropower production with the maximum deviation within the limits required by the dispatch operator. The deviation, together with other variables depicting the hybrid operation, can be seen in figure 2.27.

**FIGURE 2.27. Hybrid operation on a sunny day (top) and a cloudy day (bottom) during daylight hours.**

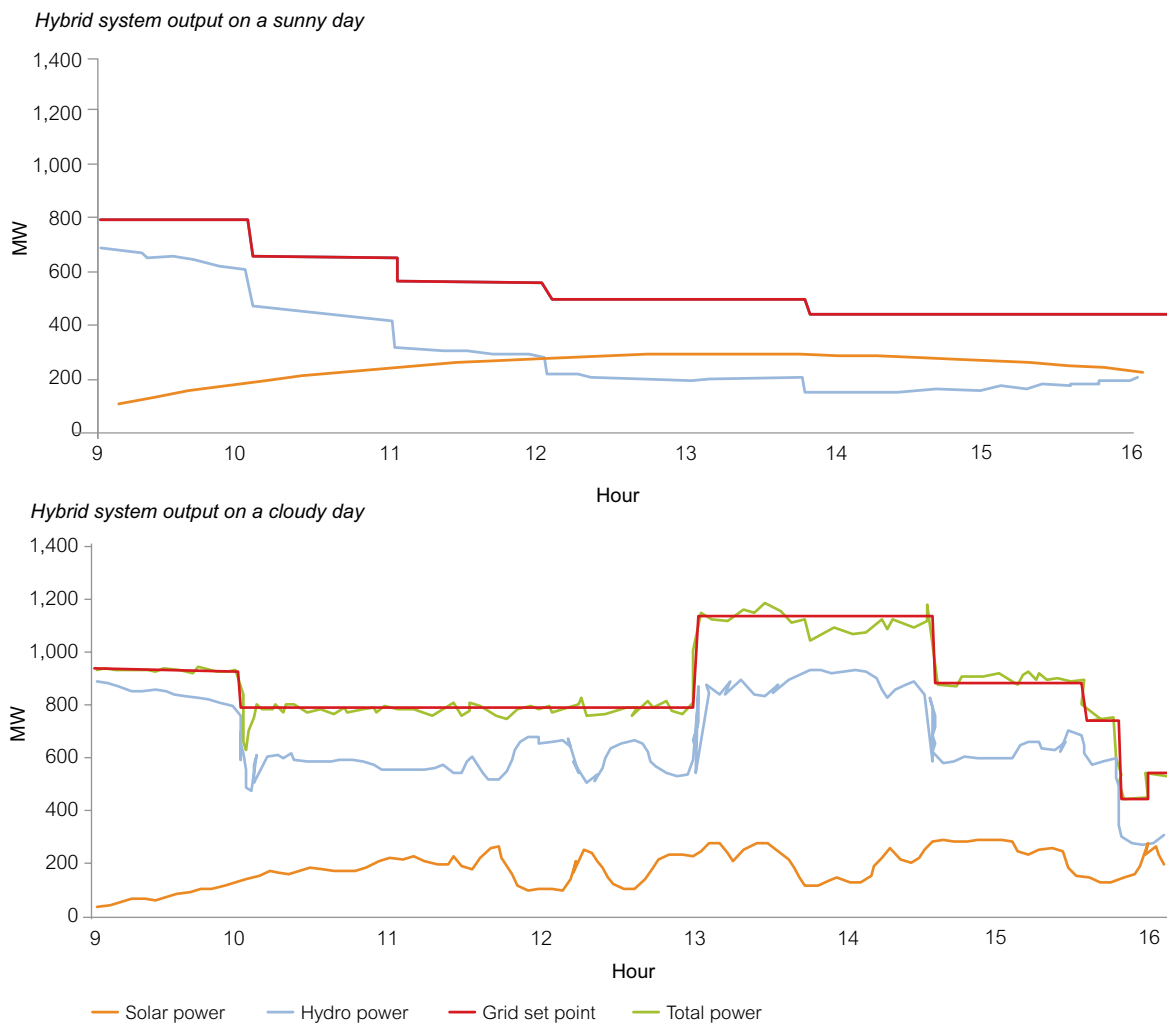

Source: SERIS based on Qi 2014.

Note: Total power plot is not visible on the top graph since Grid set point plot mostly corresponds to the same values as Total power plot.

Field operations have shown that the hydropower turbines can provide adequate response to variations in demand and PV output. The active power ramp rate of four turbines exceeds 150 MW per minute, and the maximum output deviation is 60 MW. These parameters meet grid-dispatch requirements.

---

## References

- An, Y., and others. 2015. Theories and methodology of complementary hydro/photovoltaic operation: Applications to short-term scheduling. *Journal of Renewable and Sustainable Energy* 7(6): 063133.
- Connor, P.M. 2009. Performance and prospects of a lightweight water-borne PV concentrator, including virtual storage via hydroelectric-dams. *Proceedings of the ISES Solar World Congress 2009: Renewable Energy Shaping Our Future*.
- Fang, W., and others. 2017. Optimal sizing of utility-scale photovoltaic power generation complementarily operating with hydropower: A case study of the world's largest hydro-photovoltaic plant. *Energy Conversion and Management* 136: 161–172.
- Gebretsadiq, Y., and others. 2016. Optimized reservoir operation model of regional wind and hydro power integration case study: Zambezi basin and South Africa. *Applied Energy* 161: 574–582.
- Gong, C., and others. 2014. AGC control strategy and application in Longyangxia Hydro/PV complementary operation. *Mechanical and Electrical Technique of Hydropower Stations* 37(3): 63–64.
- Kim, S.-H., and others. 2016. Application of floating photovoltaic energy generation systems in South Korea. *Sustainability* 8(12): 1333.
- Mousazadeh, H., and others. 2009. A review of principle and sun-tracking methods for maximizing solar systems output. *Renewable and Sustainable Energy Reviews* 13(8): 1800–1818.
- Patil Sujay, S., M.M. Wagh, and N.N. Shinde. 2017. A review on floating solar photovoltaic power plants. *International Journal of Scientific & Engineering Research* 8(6).
- Planair and PITCO. 2017. *Assessment of Floating Solar PV Potential for Pakistan; Task 1: Commercial Readiness of FSPV—Global Market and Performance Analysis*. Unpublished report prepared for International Finance Corporation, Washington, DC.
- Qi, S. 2014. The analysis of complementation in PV grid-connected plant of Longyangxia 320MWp. Engineering Department, Xi'an University of Technology.
- Rosa-Clot, M. 2018. Floating Tracking Cooling Concentrator (FTCC) System. <http://www.scintec.it/ricerca/energia/ftcE.html>.
- Rosa-Clot, M. and G.M. Tina. 2018a. Integration of water-based PV systems. In *Submerged and Floating Photovoltaic Systems* (chapter 9). Academic Press.
- Rosa-Clot, M. and G.M. Tina. 2018b. Concentration systems and floating plants. In *Submerged and Floating Photovoltaic Systems* (chapter 6). Academic Press.
- Rosa-Clot, M. and G.M. Tina. 2018c. Submerged PV systems. In *Submerged and Floating Photovoltaic Systems* (chapter 4). Academic Press.
- Tina, G.M., M. Rosa-Clot, and P. Rosa-Clot. 2011. Electrical behavior and optimization of panels and reflector of a photovoltaic floating plant. Proceedings of 26th European Photovoltaic Solar Energy Conference and Exhibition, Hamburg, Germany.
- Trapani, K. and D.L. Millar. 2014. The thin film flexible floating PV (T3F-PV) array: The concept and development of the prototype. *Renewable Energy* 71: 43–50.

- Trapani, K. and M. Redón Santafé. 2015. A review of floating photovoltaic installations: 2007–2013. *Progress in Photovoltaics: Research and Applications* 23(4): 524–532.
- World Bank Group, ESMAP and SERIS. 2019. “Where Sun Meets Water: Floating Solar Handbook for Practitioners.” Forthcoming. Washington DC: World Bank.
- Zhang, P. and T. Yang. 2015. The study of operation strategy of Longyangxia Hydro/PV complementary operation. *Journal of North China University of Water Resources and Electric Power* (Natural Science Edition) 36(3): 76–81.





# 3 GLOBAL MARKET AND POTENTIAL

## 3.1. Availability of floating solar resource

Where does it make the most sense to harness the sun’s energy using photovoltaic (PV) panels floating on water? In this section, global hotspots for floating photovoltaic (FPV) installations are assessed by looking at (i) global irradiation data and (ii) the locations of water bodies such as lakes, reservoirs, dams, and ponds. A third factor, also key, is the availability of nearby electric power lines but such evaluation would require localized prefeasibility studies.

### 3.1.1. Global irradiation

Global horizontal irradiation (GHI) generally decreases as one moves away from the equator to the north and south. Looking at a color-coded map of long-term average yearly GHI, this is indicated by a shift from warm tones (pink and red) to cool ones (green and blue) (see figure 3.1). The irradiation data used for this study were obtained from the Global Solar Atlas provided by the World Bank Group and funded by the Energy Sector Management Assistance Program (ESMAP). Irradiation rates were calculated using atmospheric and satellite data, and considering the effects of terrain, with a spatial resolution of 1 km. Note that uncertainty ranges from about 3 percent to 10 percent, depending on the location.

**FIGURE 3.1. Average GHI levels around the world**

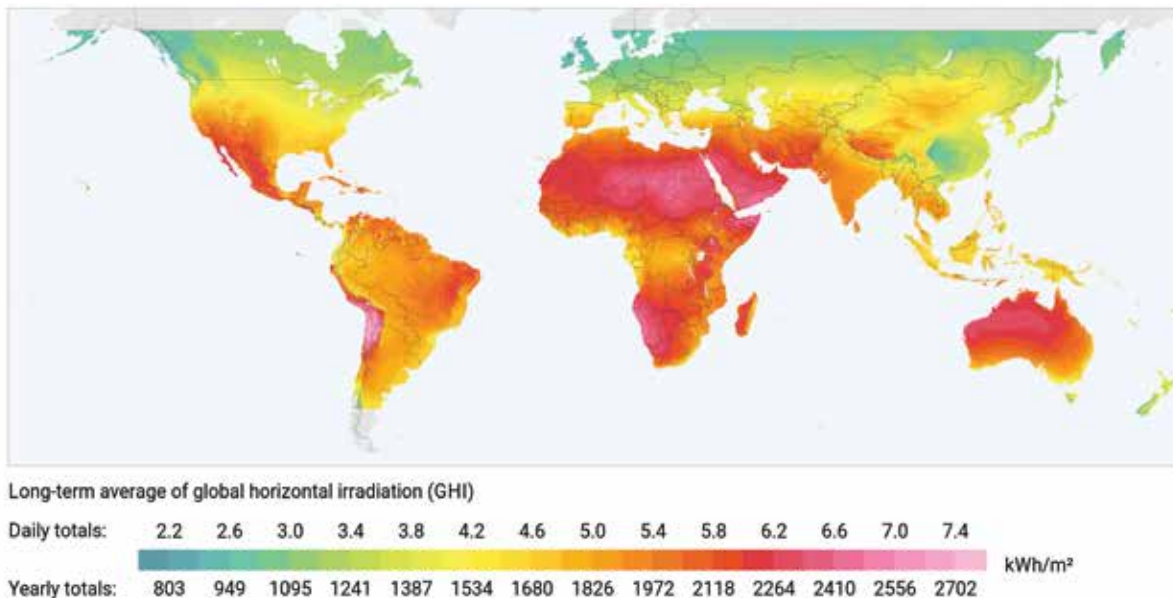

Source: Global Solar Atlas (<https://globalsolaratlas.info>), © World Bank Group (2019).  
 Note: kWh/m<sup>2</sup> = kilowatt-hour per square meter.

### 3.1.2. Availability of water bodies

Water bodies are of two main types: natural and man-made. This study considers only man-made reservoirs and dams, using data from the Global Reservoir and Dam Database (GRanD) compiled by Lehner and others (2011b) and distributed by the Global Water System Project (GWSP) and the Columbia University Center for International Earth Science Information Network (CIESIN). Natural water bodies are not considered here, for a couple of reasons: (i) to compile a complete global list of natural water bodies (approximately 177 million) would be a cumbersome task, and, also (ii) environmental considerations that apply to these are different than for man-made water bodies.

There are several databases of man-made water bodies. For example, the Food and Agriculture Organization of the United Nations developed AQUASTAT, a geo-referenced database of dams and associated reservoirs, which was used as an input when GRanD was set up.

This analysis utilizes GRanD instead of the AQUASTAT database for the following reasons:

- **Geo-referencing.** Although the number of total reservoirs in the AQUASTAT database is higher, the number with geo-coordinates is lower than in GRanD.
- **Greater detail.** GRanD offers more details on its data sources, selection criteria, and methods used to compile and document data (FAO 2016).

The following steps were carried out during the assessment:

- Using geographic information system (GIS) data, all the selected water body vectors were charted onto a global solar irradiation map, and the surface area of each water body was calculated. This resulted in a detailed list of the average irradiation potential of the world's man-made water bodies.
- This average potential would only be realized if 100 percent of these water bodies' surface were to be utilized. This is the theoretical maximum deploy-

ment limit, but it is far from realistic due to feasibility and environmental concerns.

- A range of 1–10 percent of the total surface area is defined as “useable” for the purposes of this analysis. It is assumed that covering this much of the surface area would not have significant adverse impacts on the environment (although in practice this should be investigated specifically for each reservoir). This does not mean that a higher surface coverage ratio could not be considered, as seen in various realized projects worldwide, but this will depend on the specificities of each reservoir.
- This useable area was then multiplied by an area factor of 100 watt-peak per square meter (Wp/m<sup>2</sup>), which is within the range reported by existing FPV projects.<sup>4</sup> This results in a total installed peak capacity in gigawatt-peak (GWp).
- In order to derive the potential electricity generation, the installed capacity was multiplied by the energy yield, using the local irradiation with a standardized assumption of an 80 percent performance ratio (PR).

The potential capacity and energy generation of FPV projects are summarized by continent in table 3.1. The continent of Antarctica is omitted because of its relatively low irradiation and low power demand.

If just 1 percent of man-made reservoir surfaces were used, FPV capacity could quickly reach 400 GWp, which is the total installed capacity of all conventional solar PV systems combined at the end of 2017. Even if only 10 percent of the surface area of every third man-made reservoir in the world were covered, the FPV market would represent a terawatt (1,000 GW) scale market opportunity. That is before even tapping the resource potential of the world's natural landlocked water bodies or its oceans—which receive the majority of the solar energy received on earth.

4. The projects investigated include (i) Yamakura Dam Reservoir, Japan; (ii) Umenoki, Japan; (iii) Agongdian Reservoir, Taiwan, China; (iv) Godley Reservoir, United Kingdom; and (v) Queen Elizabeth II, United Kingdom.

**TABLE 3.1. Floating photovoltaic potential, capacity and energy generation by continent**  
(man-made reservoirs and dams only)

Continent	Total surface area available [km <sup>2</sup> ]	No. of water bodies assessed	Total FPV capacity potential [GWp] (% of water surface used for PV installation)			Total annual FPV energy output potential [GWh/y] (% of water surface used for PV installation)		
			1%	5%	10%	1%	5%	10%
Africa	101,130	724	101	506	1,011	167,165	835,824	1,671,648
Asia*	115,621	2,041	116	578	1,156	128,691	643,456	1,286,911
Europe	20,424	1,082	20	102	204	19,574	97,868	195,736
N. America	126,017	2,248	126	630	1,260	140,815	704,076	1,408,153
Oceania	4,991	254	5	25	50	6,713	33,565	67,131
S. America	36,271	299	36	181	363	58,151	290,753	581,507
<b>Total</b>	<b>404,454</b>	<b>6,648</b>	<b>404</b>	<b>2,022</b>	<b>4,044</b>	<b>521,109</b>	<b>2,605,542</b>	<b>5,211,086</b>

Source: SERIS calculations based on the Global Solar Atlas, © World Bank Group (2019) and the GRanD database, © Global Water System Project (2011).

Notes: \*Middle East is included in Asia. FPV = floating photovoltaic; GWh/y = gigawatt-hour per year; GWp = gigawatt-peak; km<sup>2</sup> = square kilometer; PV = photovoltaic.

**FIGURE 3.2. FPV capacity potential worldwide based on total surface area available**

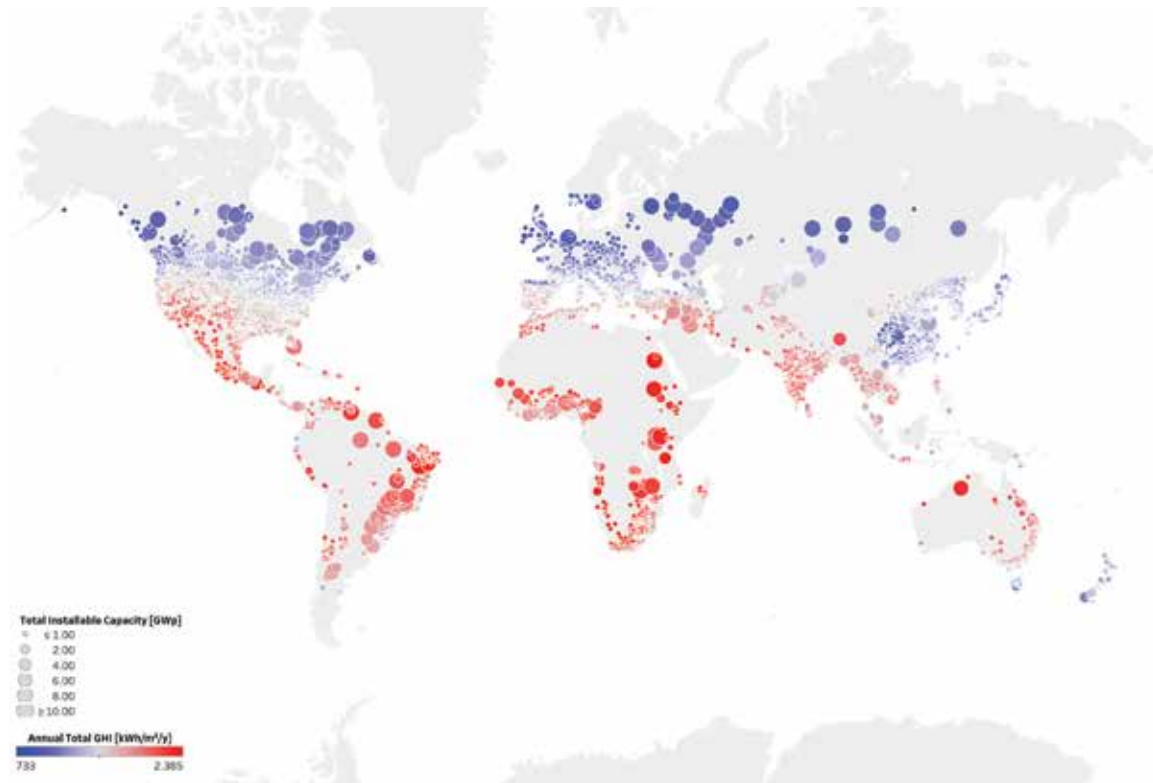

Source: SERIS based on the Global Solar Atlas, © World Bank Group (2019) and the GRanD database, © Global Water System Project (2011).

Note: GWp = gigawatt-peak; kWh/m<sup>2</sup>/y = kilowatt-hour per square meter per year; kWp/m<sup>2</sup> = kilowatt-peak per square meter; PV = photovoltaic.

The global potential is outlined in the global map presented in figure 3.2, under the assumption that up to 10 percent of man-made water surfaces are covered. The size of the circles indicates the size of the considered reservoirs' FPV potential.

### 3.2. Current market status

The world market for FPV has been surging over the past few years (as outlined in chapter 1), and the installed capacities of individual projects are increasing year on year. The largest FPV systems in operation are in China, where two projects with capacities of 150 megawatt-peak (MWp) each were developed by Sungrow Group and China Three Gorges New Energy Co., Ltd. The global installed FPV capacity exceeded 1.3 GWp as of December 2018 and has been growing exponentially since 2017. Table 3.2 lists the world's largest FPV projects (with capacities of at least 5 MWp) completed as of December 2018.

Market data suggests that with the installation of a few large FPV systems in the last two years China has become the FPV market leader with installed capacity

of more than 950 MWp, representing about 73 percent of the world's total. The remainder of the installed capacity is mainly spread between Japan (about 16 percent), the Republic of Korea (about 6 percent), Taiwan, China (about 2 percent), the United Kingdom (about 1 percent) whilst the rest of the world accounts for only 2 percent. FPV plants totaling more than 180 MWp have been installed to date in Japan; most of them are below 3 MWp.

Figure 3.3 ranks the FPV projects listed in Table 3.5 as well as projects smaller than 5 MWp based on their installed capacity. Plants were divided into five categories: (i) smaller than 2 MWp, (ii) between 2 and 3 MWp, (iii) between 3 and 5 MWp, (iv) between 5 and 15 MWp, and (v) larger than 15 MWp. Most of the installations to date are small systems with capacities below 3 MWp. However, the number of large systems has been increasing significantly since 2017 and this trend is set to continue, with many FPV projects larger than 10 MWp under development. The world's 13 largest plants (>15 MWp) account for more than 70 percent of all FPV installed capacity.

**FIGURE 3.3. Distribution of FPV plants according to their size, as of December 2018**

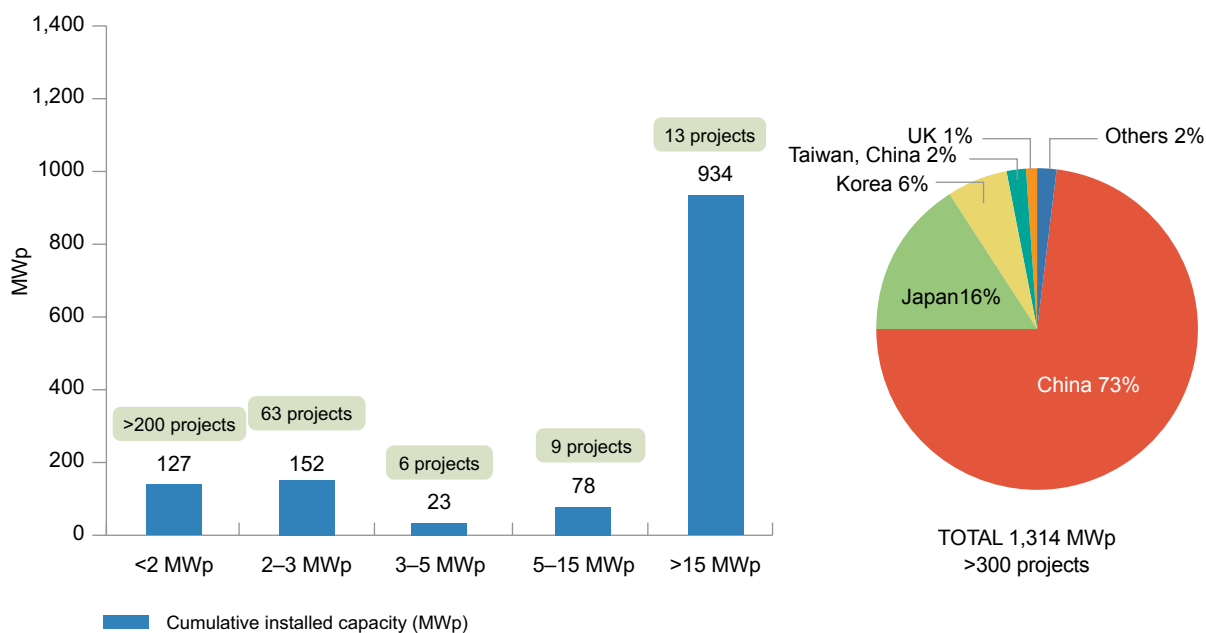

Source: Authors' compilation based on various external sources (public media releases and direct insights from industry representatives).  
Note: MWp = megawatt-peak. List of projects attempts to be exhaustive, but omissions might have occurred.



**TABLE 3.3. Overview of largest (5 MWp and above) FPV installations in the world, ranked by size, as of December 2018**

Size (kWp)	Water body and nearest city	Country	City/Province	Floating system supplier(s) (and subcontractor, if applicable)	Completion year
150,000	Coal mining subsidence area, Huainan City (Panji—China Three Gorges New Energy)	China	Anhui Province	Beijing NorthMan, Zhongya, Hefei Jintech New Energy Co. Ltd., Anhui ZNZN New Energy Co. Ltd., CJ Institute China	2018
150,000	Coal mining subsidence area, Huainan City (Fengtai Guqiao—Sungrow)	China	Anhui Province	Sungrow Floating (Anhui ZNZN New Energy Technology Co. Ltd.)	2018
130,000	Yingshang coal mining subsidence area (Liuzhuang mine—Trina Solar)	China	Anhui Province	Anhui ZNZN New Energy Technology Co. Ltd., Shanghai Qihua Wharf Engineering Co. Ltd, etc.	2018
102,000	Coal mining subsidence area, Huainan City (Fengtai Xinji)	China	Anhui Province	Sungrow Floating (Anhui ZNZN New Energy Technology Co. Ltd.)	2017
100,000	Coal mining subsidence area, Jining City	China	Shandong Province	Sungrow Floating	2018
70,005	Mine lake, near Huaibei (China Energy Conservation and Environmental Protection (CECEP))	China	Anhui Province	Ciel & Terre International	2018
50,000	Coal mining subsidence area, Jining City (Shandong Weishan)	China	Shandong Province	Sungrow Floating	2017
40,000	Renlou coal mine in Huaibei City (Trina Solar)	China	Anhui Province	Shanghai Qihua Wharf Engineering Co. Ltd., etc.	2017
40,000	Coal mining subsidence area, Huainan City (20+20 Panji)	China	Anhui Province	Sungrow Floating	2017
32,686	Mine lake (Golden Concord Ltd (GCL))	China	Anhui Province	Ciel & Terre International	2018
31,000	Coal mining subsidence area, Jining City (Shandong Weishan)	China	Shandong Province	Sungrow Floating	2017
20,000	Coal mining subsidence area, Huainan City (Xinyi)	China	Anhui Province	N/A	2016
18,700	Gunsan Retarding Basin	Korea, Rep.	North Jeolla	Scotra Co. Ltd.	2018
13,744	Yamakura Dam reservoir	Japan	Chiba	Ciel & Terre International	2018
10,982	Xuzhou Pei County	China	Jiangsu Province	Ciel & Terre International	2017
9,087	Urayasu Ike	Japan	Chiba	Ciel & Terre International	2018
8,500	Wuhu, Sanshan	China	Anhui Province	N/A	2015
8,000	Lake in Xingtai, Linxi County	China	Hebei Province	N/A	2015
7,550	Umenoki Irrigation Reservoir	Japan	Saitama	Ciel & Terre International	2015
6,800	Hirofani Ike	Japan	Hyogo	Takiron Engineering Co. Ltd.	2018
6,776	Amine Lake, Jining City	China	Shandong Province	Ciel & Terre International	2018
6,338	Queen Elizabeth II Drinking Water Reservoir	United Kingdom	London	Ciel & Terre International	2016

Source: Authors' compilation based on various external sources (public media releases and direct insights from industry representatives).

Notes: N/A = not available; kWp = kilowatt-peak; MWp = megawatt-peak; PV = photovoltaic. List of projects attempts to be exhaustive, but omissions might have occurred.

FPV offers significant advantages in countries where land is scarce or expensive, and suitable water bodies are present. Some economies, such as Taiwan, China, offer financial incentives for the use of water bodies for PV deployment. Several large FPV installations are integrated with hydropower plants. These arrangements increase the overall efficiency of both solar and hydropower production and allow the sharing of existing transmission infrastructure.

The following subsections consider the present and future FPV capacity of selected countries (presented in alphabetical order), based on available literature, including various online sources. The countries listed in this chapter have large installed FPV capacity, sizeable planned or tendered future FPV capacity, or are considering developing their near-shore and offshore potential.

### 3.2.1. Albania

Statkraft is planning to build a 2 MW FPV system at its 72 MW Banja hydropower dam. This project might be eligible for the feed-in tariff applicable in the country (Bellini 2019). The largest Albanian power producer, Korporata Elektroenergjitiqe Shqiptare (KESH), is planning to develop a 12.9 MW FPV system (Jonuzaj 2018).

### 3.2.2. Bangladesh

As of early 2019, two FPV systems are planned in the country, including one of 50 MW, which should receive the support from the Asian Development Bank and will be built on Kaptai Lake in the Chittagong district (Islam 2019).

### 3.2.3. Belgium

The first 998 kilowatt-peak (kWp) FPV system was commissioned in early 2018 at Hesbaye Frost in Geer. Other pilot FPV installations, including a 5 MWp system to be owned by Sibelco in Dessel,<sup>5</sup> are being developed and supported at the subnational level, by the Flemish government (Bellini 2018d). Meanwhile, the Belgian government is looking into the possibility of building offshore FPV plants in the North Sea.

### 3.2.4. Brazil

The first FPV system completed in Brazil in September 2017 has a capacity of 305 kWp (figure 3.4). The system was developed by Ciel & Terre International and is located on a rainwater accumulation pond in the state

5. <https://www.sibelco.com/media/sibelco-is-supporting-sustainable-energy/>.

**FIGURE 3.4. FPV system (of 305 kWp capacity) in Goias, Brazil**



Source: © Ciel & Terre International.

Note: kWp = kilowatt-peak.

of Goiás. Ciel & Terre International is also involved in the development of two other FPV plants of 4.99 MWp each, in Balbina (Amazon region) and in Sobradinho (Bahia region) (Kenning 2017a). The first phase of these two projects started in early 2016, when 1 MWp each was installed near the Balbina and Sobradinho hydroelectric power plants. The aim is to evaluate the performance of two similar systems in different climatic conditions (Zaripova 2016).

### 3.2.5. Cambodia

A 2.8 MWp FPV system developed by Cleantech Solar with floats from Ciel & Terre International was completed end of 2018 and commissioned early 2019 at Chip Mong Insee Cement Corporation industrial pond. The Natural Heritage Institute (NHI) evaluated the feasibility of installing a utility-scale FPV system on the recently built 400 MW Lower Se San 2 Hydro-power Dam, as an alternative to the Sambor Dam and hydroelectric power plant project (National Heritage Institute 2017).

### 3.2.6. China

Multiple pilot and small-scale projects were developed in China before early 2016, when large projects started to take off. Since then, the country has seen astounding growth: total installed capacity was more than 950 MWp as of December 2018, surpassing by far the combined capacity of all other countries in the world. The large majority of China's FPV projects are located in Anhui Province and utilize lakes formed when irregular depressions in the terrain caused by the collapse of mines flooded with rainwater. A further 400 MW was tendered in Shandong Province; this combines FPV with "PV over water," that is, installed on piles in shallow water. The winning bidders (among them Sungrow, Trina, GCL, Xinyi, CECEP, and China Three Gorges New Energy) sell the generated electricity to the State Grid Corporation of China at rates ranging from yuan (Y) 0.71 to Y 0.81 per kilowatt-hour (kWh) (\$0.11–0.12/kWh). Many of these large-scale FPV systems (including systems

developed by Xinyi, Trina Solar and Sungrow) are unique in the way that they used central inverters and transformers on dedicated floating pontoons, allowing for shorter direct current (DC) cabling (Planair and PITCO 2017).

Currently, the largest FPV plants in operation are two 150 MWp projects, one completed by Three Gorges New Energy Company and the other by Sungrow. Both are located in Anhui Province. Additional projects under China's "Top Runner" program were disclosed in 2017, but how many of these will be realized remains to be seen (Bin 2018).

### 3.2.7. Colombia

A 99 kWp FPV system, consisting of two units, was recently completed in 2018. The system was deployed on the water reservoir of Peñol-Guatapé, owned and operated by Empresas Públicas de Medellín (EPM), the local energy and telecommunications utility of Medellín (Bellini 2018a; Ciel & Terre International 2018). New large-scale projects are in the pipeline.

### 3.2.8. France

In France, a flagship project, O'MEGA 1, is being developed in Piolenc in the department of Vaucluse. The 17 MWp project, developed by Akuo Energy, is under construction and expected to be completed in March 2019. It is built on a former quarry lake and will be financed through nonrecourse project financing from Natixis Energenco (Kenning 2018a). Other large-scale FPV projects are currently under development in Hautes Alpes and Bouches-du-Rhône regions.

### 3.2.9. Ghana

In February 2018, Eni Ghana and Eni Energy Solutions signed two separate memorandums of understanding (MOUs) with Bui Power Authority, the company responsible for the management of the 400 MW Bui Hydroelectric Power Project in Ghana, and Volta River Authority, respectively. Both relate to the joint development of power generation from renewable sources, including FPV systems (Eni.com 2018).

### 3.2.10. India

India's numerous hydropower plants have a total capacity of 44 GW (equivalent to 13.6 percent of India's total energy output), offering tremendous potential for the integration of FPV and hydropower. India's largest FPV plant to date is a 2 MWp FPV system, installed on the Mudasarlova reservoir in Visakhapatnam (Andhra Pradesh) and developed by Greater Visakhapatnam Smart City Corporation Limited, a company created in 2016 to implement various smart city projects (Prateek 2018b). Another 3 MWp FPV project on the Meghadrigedda reservoir in Visakhapatnam, tendered in 2017 by the Greater Visakhapatnam Municipal Corporation, was recently awarded to ReNew Power Limited (ReNew Power 2018). The corporation is planning to build another 15 MWp FPV system on the Meghadrigedda reservoir (Rao 2018).

Given the relative shortage of inexpensive land and very ambitious solar targets in the country, India's FPV project pipeline is growing fast, with many large-scale projects under study. A 5 MWp plant is currently under construction in the district of Murshidabad in West Bengal following a turnkey engineering, procurement, and construction tender won by International Coil Ltd. at a price of Rs. 269.12 million (about \$4.1 million, or \$0.83 per Wp) (Prateek 2018a).

National Hydroelectric Power Corporation has announced plans to set up a 600 MWp FPV at the 1,960 MW Koyna Hydropower project, with an estimated capital cost of \$1,350–\$1,500/MWp (Saurabh 2016). In addition, an FPV project of 5 MWp has been planned by the mining and power firm NLC India, in the Andaman and Nicobar Islands (Planair and PITCO 2017). Two projects totaling 40 MWp in Maharashtra and Kerala, funded by KfW Development Bank, were announced in 2016, with an investment of \$44 million (Planair and PITCO 2017).

In December 2017, the Solar Energy Corporation of India (SECI) announced an expression of interest in 10 GWp of FPV on artificial bodies of water across the country, with the aim of gathering information on their feasibility through market consultations (Ken-

ning 2017c). In 2018, SECI launched a tender for three FPV projects with 50 MWp capacity each at the Rihand Dam, located in the Sonbhadra district of Uttar Pradesh. An upper ceiling tariff of Rs. 3.32 (~\$0.047<sup>6</sup>)/kWh has been fixed for this tender. Shapoorji Pallonji won package B (50 MWp) with a tariff of Rs. 3.29/kWh (Kabeer 2018). Additional projects are foreseen in Tamil Nadu, Jharkhand, and Uttarakhand.

In November 2017, the Lakshadweep Energy Development Agency invited developers to submit an expression of interest in FPV projects of 10 MWp in the Lakshadweep islands. In June 2018, the National Thermal Power Corporation launched a tender for a 22 MW FPV system to be developed at the Rajiv Gandhi Combined Cycle Power Plant in Kayamkulam in Kerala. The project would be financed by the same corporation that launched it (Prateek 2018c). In the same month, the Irrigation and Water Resource Department of Uttar Pradesh issued a tender to develop 100 MW of grid-connected canal-top solar PV (ground-mounted, not FPV) projects under a public-private partnership model (Prateek 2018d). The Maharashtra State Electricity Distribution Company is also looking at developing 1 GWp of FPV at the Ujani Dam in Solapur District (Kenning 2018b).

Many other new FPV tenders have been launched end of 2018 and early 2019, some of which by NTPC Limited, one of the largest power utilities in the country, with the aim to build FPV systems at its existing power plants. Most recently, TANGEDCO from Tamil Nadu announced a plan to open tenders for 250 MW of FPV systems on three dam reservoirs in the state (Sivakumar 2019).

### 3.2.11. Indonesia

Indonesia has significant FPV potential, and one of the major developers in the country, the Abu Dhabi-based Masdar Clean Energy, is looking ahead in that direction. Many forested areas across the islands of Indonesia are not suitable for solar deployment, and

6. Exchange rate as of August 31, 2018.



**FIGURE 3.5. FPV installation** (with a capacity of 13.7 MWp) **at the Yamakura Dam in Japan**



Source: © Kyocera TCL Solar LLC.  
Note: MWp = megawatt-peak.

land prices are high. The company has identified more than 60 reservoirs that could host FPV plants. Recently, Masdar signed a project development agreement with the local power utility PT Pembangkitan Jawa-Bali to build a 200 MWp FPV plant covering 225 hectares of the surface area of the Cirata Hydroelectric Plant Reservoir in West Java Province (Rambu Energy 2017; Publicover 2017b). The Asian Development Bank also performed a preliminary opportunity assessment of FPV in Sulawesi and Kalimantan by identifying six sites with a cumulative capacity of 975 MWp. It estimates FPV potential to be in the range of several gigawatts at similar sites (e.g., hydropower reservoirs, estuaries, bays) across the country.

### 3.2.12. Italy

Several companies in Italy are pioneering the development of FPV systems, such as Koine Multimedia, with its floating tracking cooling concentrator, and NRG Energia. One of the largest systems to date is the 343

kWp Pontecorvo system located on an irrigation pond in Savona Province, completed by Ciel & Terre International.<sup>7</sup>

### 3.2.13. Japan

Japan is the country with the longest history of MW-scale floating PV installations. The first 20 kWp project was completed in 2007 in Aichi, Japan, as a research prototype by the National Institute of Advanced Industrial Science and Technology. It is estimated that more than 180 MWp of FPV systems were deployed in Japan by end 2018. FPV offers many benefits to Japan given its mountainous and heavily forested terrain (over 70 percent of its land is unsuitable for ground-mounted PV). Japan also has abundant water surfaces; over 200,000 agricultural reservoirs are used for irrigation or rainwater retention, among its

7. [https://www.ciel-et-terre.net/essential\\_grid/floating-solar-system-pontecorvo-34320-kWp/](https://www.ciel-et-terre.net/essential_grid/floating-solar-system-pontecorvo-34320-kWp/).



**FIGURE 3.6. Offshore FPV system in the Maldives**



Source: © Swimsol.

many lakes, dams, and reservoirs (Planair and PITCO 2017). Japan used to benefit from a generous feed-in tariff (FiT) scheme for both small- and large-scale solar PV systems (FiTs for FPV were the same as for ground-mounted PV). However, the subsidy scheme was revised in 2017, when FiTs were removed for solar systems larger than 2 MWp.<sup>8</sup>

The world's second-largest FPV installation outside China is on the Yamakura water retention dam in Chiba Prefecture, with a capacity of 13.7 MWp (MI News Network 2017) (figure 3.5).

### **3.2.14. Lao People's Democratic Republic**

A Japanese company, TSB Co. Ltd., plans to build a 14 MWp FPV plant at Nongheo and Nahai water ponds in Hadxaifong district, near Vientiane (Vientiane Times 2018). The Natural Heritage Institute developed a master plan (National Heritage Institute 2018) that was submitted to the government of Lao PDR in February 2018. The master plan examines the deployment of FPV at the largest existing hydro-

8. <https://www.iea.org/policiesandmeasures/pams/japan/name-30660-en.php>.

power reservoir in the Xe Kong Basin, the 290 MW Xe Kaman 1 hydropower plant, as an additional source of electricity generation. The plan was endorsed by the prime minister, who issued two directives (dated February 16 and August 13, 2018) to the relevant line ministries to adopt and implement its findings and recommendations to further the nation's renewable energy development.

### **3.2.15. Malaysia**

About 78 lakes in peninsular Malaysia have been identified as suitable for developing FPV systems (Reve 2015). Malaysia's largest FPV project to date was built by Cypark Renewable Energy, a subsidiary of Cypark Resources Berhad (CRB), on Ulu Sepri Dam, a reservoir for drinking water. CRB partnered with Ciel & Terre International in this 270 kWp FPV installation, which was connected to the grid in November 2016 and which benefits from the feed-in tariff that was in place at the time (PV Tech 2018b; Ciel & Terre International 2018). CRB plans to build two more projects, each 30 MW, one at Terip Dam and one at Kelinchi Dam in Negeri Sembilan under a contract with Cove Suria (PV Tech 2018b). The company from Taiwan, China Tien Ching Energy along with UMILE signed a memoran-

dum of understanding for a 48 MWp FPV project with an estimated investment of up to \$90 million (Planair and PITCO 2017). In December 2017, the winners of the country's second large-scale solar PV auction were announced; four of the winning projects are FPV, including a 9.99 MW to be developed by Coral Power Sdn Bhd in Manjung, Perak (Bernama 2018). These projects are expected to start commercial operation between 2019 and 2020. In April 2018, Sarawak's chief minister made a proposal to LONGi to explore the possibility of developing FPV systems at dams and rivers in the state (The Sun Daily 2018).

### 3.2.16. Republic of Maldives

In the Maldives, Swimsol developed the first offshore FPV systems in 2014. These offshore projects are of a small scale and meant to be complementary to rooftop PV installations as a means to reduce island resorts' reliance on expensive diesel generators (figure 3.6). In 2018, eight different platforms with a total capacity of 200 kWp have been installed at various locations by the same company. New projects are currently being developed. Early 2019, the government published a tender to install 5 MW of grid-tied solar PV systems in the Greater Male region. Even though floating PV is not being specified in the tender documents, such technology could be considered for future tenders.

### 3.2.17. The Netherlands

The Netherlands has 52,000 hectares of shallow inland waters that could potentially be used for FPV installations. In 2017, a national consortium called "Zon op Water", Sun on Water, was created, initiated by the Ministry of Infrastructure and Water management, and led by the Solar Energy Application Center (SEAC). The consortium comprises more than 40 companies with the aim to promote the development and installation of 2 GWp of FPV in the Netherlands by 2023. The consortium is developing a series of projects, including one on the permitting regulatory framework as well as multiple testbeds in various environments (e.g., inland, sea, with varying levels of wave and wind exposure).

One of these testbeds was initiated by Waterschap Rivierenland, the Dutch Water Authority partnering with Dutch companies Blue21 BV, Hakkers BV, and the Photovoltaic Materials and Devices unit (PVMD) of Netherlands' Delft University of Technology (TU Delft). The consortium is named INNOZOWA (INNOvatieve ZOn-pv op Water) and is financially supported by the government-run Netherlands Enterprise Agency (Bellini 2018e).

In addition, the "Zon op Water" consortium installed four FPV systems of 50 kWp each on De Slufter, a contami-

**FIGURE 3.7. FPV installation (with a capacity of 1.85 MW) in Azalealaan, Netherlands**



Source: © Ciel & Terre International.  
Note: MWp = Megawatt-peak.

nated dredging depot in the Port of Rotterdam, to function as a pilot testbed. The companies involved include Wattco, Texel4Trading, Sunprojects, and Sunfloat.<sup>9</sup> If this pilot proves successful, as much as 100 MWp of capacity could be developed at this site (Osborne 2017b). The project aims to demonstrate the feasibility of FPV installations on rough waters. The pilot is located in a tough environment where the water is brackish, contains many contaminants, and where wind and waves with heights up to 1 meter are common.

Also under the aegis of “Zon op Water,” a consortium formed by the Energy Research Centre of the Netherlands, the Netherlands Organization for Applied Scientific Research, the Maritime Research Institute Netherlands, the Abu Dhabi National Energy Company PJSC, and the Dutch startup Oceans of Energy, announced in February 2018 that it would develop and deploy an offshore FPV project (“Solar@Sea”) over the next three years. The panels’ performance will be tested in salt water and inclement weather conditions (Bellini 2018b). The testbed will be financially supported by the Netherlands Enterprise Agency.

A 780 MWp FPV system at De Krim Resort, Texel Islands, has been tendered by Texel4Trading on a rain-water reservoir currently used to irrigate golf courses. Additionally, a 1.85 MWp FPV system was recently built

on a local reservoir near Lingewaard in the eastern Netherlands (Doo-soon and Ha-yeon 2018) (figure 3.7).

In September 2018, the water utility NV PWN Waterleidingbedrijf Noord-Holland launched a tender to select a contractor to design, supply, and install FPV systems with a combined capacity of 7 MWp at two different locations (Andijk and Hoofddorp). Projects could be expanded in the future to 16.7 MWp (Tsanova 2018).

### 3.2.18. Norway

Ocean Sun has successfully tested in Norway two offshore floating PV systems, based on their hydroelastic membrane concept. A third system of 100 kWp supplies off-grid power (with back-up diesel generators) since April 2017 to a large fish farm on the western coast of Norway. More projects are in the pipeline to power other fish farms in Norway, as well as install such system on hydropower dams.

### 3.2.19. Panama

In February 2017, a 24 kWp project was completed and connected to the grid by Ciel & Terre International<sup>10</sup> on a water retention pond (figure 3.8). It consists

9. <https://www.zonopwater.nl/>

10. [https://www.ciel-et-terre.net/essential\\_grid/fl/](https://www.ciel-et-terre.net/essential_grid/fl/).

**FIGURE 3.8. FPV system (with 24 kWp capacity) at Miraflores near the Panama Canal**



Source: © Ciel & Terre International.

Note: kWp = kilowatt-peak.

**FIGURE 3.9. FPV system in Alto Rabagão in Portugal**



Source: © Pixbee/EDP S.A.

of 96 solar panels located in a semi-closed recess of the great Gatun Lake and close to the Miraflores locks, on the Pacific side of the Panama Canal (Panama Today 2017).

### **3.2.20. Portugal**

The first FPV project to be built at an existing hydro-electric power station was at a dam at the mouth of the Rabagão River in Montalegre, Portugal. The 220 kWp system occupies an area of around 2,500 m<sup>2</sup>. The pilot project was initiated by Energias de Portugal (EDP) in 2015 and has been operational since the end of November 2016 (figure 3.9). The mooring of this floating power plant was very challenging, as the bottom of the reservoir is more than 60 meters deep, and the system must deal with a regular fluctuation in water level of up to 30 meters (Osborne 2017a).

### **3.2.21. Seychelles**

The first African utility-scale FPV tender was announced in April 2018 for a 4 MW system on Mahé Island, in the Seychelles (Beetz 2018). The tender is organized by the Seychelles Energy Commission with support from the African Legal Support Facility of the African Development Bank and the Clinton Foundation. The project will be one of the first in the world to be installed on a

shallow body of salt water separated from the sea by an industrial estate.

### **3.2.22. Singapore**

Launched in October 2016, Singapore operates the world's largest FPV testbed, with a total installed capacity of 1 MWp (figure 3.10), located on Tengeh Reservoir. The project was a collaborative initiative by PUB, Singapore's National Water Agency, and the Singapore Economic Development Board (EDB). It was designed, implemented, and is operated by the Solar Energy Research Institute of Singapore (SERIS) at the National University of Singapore. It enables observers to compare the performance of 10 FPV installations (100 kWp each) to each other and to a reference 20 kWp rooftop PV system that is mounted on top of an inverter room located on the bank of the reservoir. The testbed also allows to study its own environmental impacts on the reservoir, such as reduced evaporation as well as effects on water quality and biodiversity. A comprehensive monitoring system tracks more than 500 parameters in real time, ranging from electrical to meteorological and module-related factors. Inertia sensors track movements of the floating structures along six degrees of freedom. The 10 subsystems (see table 3.3 for an



**FIGURE 3.10. SERIS FPV testbed (with a 1 MWp capacity) at the Tengeh Reservoir in Singapore**



Source: © SERIS.

Note: MWp = megawatt-peak.

**TABLE 3.3. Key elements of SERIS FPV testbed at the Tengeh Reservoir**

System	Floating platform	Modules*	Tilt	Other features
1a	Floats and stainless steel	Glass-glass, frameless	7° east	Small water footprint
1b	Pipes and aluminum	Framed	7° east	Small water footprint
2	Pure floats	Framed	12° east and west	Dual-pitch design
3	Pure floats	Framed	12° east	—
4	Pure floats	Framed	12° east	Active cooling
5	Individual float modules	Framed and frameless, glass-glass	10° east	Good ventilation, wind load adaptation
6	Pipes and metal structure	Framed	5° east	—
7	Floats and aluminum	Framed multi-Si, half-cut multi-Si, bifacial mono-Si	7° east	Rigid structure
8	Pure floats	Framed multi-Si, bifacial mono-Si	10° east	—
9	Pure floats	Frameless, glass-glass	10° east and west	—
10	Pure floats	Framed multi-Si	15° east	—
Rooftop reference system	—	Half-cut, bifacial mono-Si	7° east	Free standing on rooftop

Source: SERIS.

Note: \*All systems use multi-Si modules unless otherwise stated.



overview) use largely different types of PV modules (including some bifacial and frameless glass-glass modules), inverters, and floating structures. One of the systems includes an “active cooling” feature: water is sprayed on to the solar modules to cool them down and thus improve their performance.

Singapore has great FPV potential, given its limited land mass and the fact that water bodies make up about 8 percent of the surface area (quarries and reservoirs are mainly used to capture rain water to generate potable water). Ongoing studies are considering how much of those water bodies can be sustainably utilized for FPV, without compromising natural habitats or the intended use of the reservoirs. Estimations of future FPV potential are in the hundreds of megawatt-peak, to be gradually developed over the years to come.

In September 2017, PUB launched tenders for engineering and environmental studies to be conducted for a potential 50 MWp FPV system in Tengeh Reservoir and a 6.7 MWp FPV system in Upper Peirce Reservoir (PUB 2017). In December 2017, Linyang Energy and Sunseap signed a memorandum of understanding to collaborate on various renewable energy and energy efficiency projects, including FPV, in Singapore (Kennin 2017f).

In 2018, the Housing Development Board announced it would initiate a research program focused on developing FPV systems in coastal marine conditions (Tan 2018). In October 2018, EDB issued a request for information to explore the feasibility of building a commercial 100 MWp FPV project on the Kranji Reservoir, where a private company (or consortium) would be first chosen as the offtaker, and in a second stage an independent power producer would be selected to build and own the system (Economic Development Board 2018). In November 2018, Sunseap announced they will develop a 5 MWp near-shore FPV system, to be located along the Straits of Johor, with the support of EDB. In April 2019, PUB called for an EPC tender for FPV deployment in the Bedok (1.5 MWp) and Lower Seletar Reservoirs (1.5 MWp) (PUB 2019).

### 3.2.23. The Republic of Korea

Together with Japan, Korea was one of the first countries to adopt FPV. As of December 2018, FPV projects with a combined capacity of more than 75 MWp had been installed with many projects in the pipeline. About 90 percent of the country’s mines have been closed or abandoned, and where collapsed mines have flooded, this means a huge FPV potential. Various floating technologies have been developed and tested by Korean companies such as the state-owned water management company Korea Water Resources Corporation (K-Water), the Korea Rural Community Corporation, and the Korea East-West Power Corporation. One tracking design features a floating structure that rotates on the water’s surface to cope with freezing conditions and ice formation on the lake.

In 2013, Korea introduced its first megawatt-scale FPV power plant, at the cooling water intake channel of the thermoelectric power plant in Dangjin-si (Planair and PITCO 2017). The world’s largest (18.7 MWp) FPV project outside China was completed in June 2018 and is located on the Gunsan Retarding Basin in North Jeolla (Scotra 2018). Another notable FPV installation has a capacity of 0.465 MWp and was developed by Solkiss in 2014. Called “the Sunflower,” its modules follow the sun using patented rotating motors. According to one estimate, this technology enables a 16 percent increase in energy yield over static FPV modules (Quirke 2017).

K-Water is actively looking at using its reservoirs to build FPV systems and envisions installing more than 1 GWp by 2022. In early 2016, K-Water signed an agreement with LG Electronics to build FPV projects on ponds and reservoirs throughout Korea (Publicover 2017a).

Also, the only state-owned Korean energy firm, Korea Hydro & Nuclear Power, signed a memorandum of understanding in February 2018 with renewable energy company Hwaseong Solar Energy for a 100 MWp FPV plant on Hwaseong Lake, a man-made body of water on Korea’s western shoreline. The state-owned firm is reportedly investing \$202 million in the project.

The PV panels would cover 8.3 percent of the lake's surface (Clover 2018).

The Korea Rural Community Corp. reported plans to install 280 MWp of FPV capacity over three sites by 2019 (Publicover 2017a). In August 2018, Hyundai Heavy Industries Green Energy Co. announced that it had signed a memorandum of understanding with KEPCO Plant Service & Engineering Co. to cooperate in establishing FPV power plants with a combined capacity of 170 MWp (Ji-woong and Mira 2018). In September 2018, Korea Western Power Co. signed a memorandum of understanding with Ansan City to build a 102.5 MW FPV system on Sihwa Lake in Ansan by 2020. This lake also accommodates the world's largest tidal power installation, totaling 254 MW (Yonhap News Agency 2018).

### 3.2.24. Sri Lanka

In March 2017, an international tender was announced for a 100 MW FPV plant to be located on the Maduru Oya Reservoir in the eastern part of the country (Kenning 2017e). The plant would cover around 4 percent

of the reservoir. This has been the first step in a wider plan to set up FPV plants on various dams and reservoirs, governed by the Sri Lanka Mahaweli Authority (Office of the Cabinet of Ministers 2016). The Asia Power Management Group, jointly with the Ministry of Mahaweli Development and Environment, is expected to develop a series of FPV projects that could total about 2 GWp.

### 3.2.25. Taiwan, China

Taiwan, China, stands to benefit a great deal from FPV. Available land for ground-mounted PV is limited in this economy, where much of the land is used for agriculture or is mountainous and forested. High demand for available land, meanwhile, is pushing up rent and purchase prices. Taiwan, China, has implemented a FiT regime, updated in January 2019, that favors FPV installations (NT\$4.5016, or about 14.6 cents per kWh) over ground-mounted PV (NT\$ 4.1094, or about \$13.3 cents per kWh) to promote the uptake of FPV (Ministry of Economic Affairs 2019). A slightly higher FiT is available for FPV projects connected to the high voltage transmission grid.<sup>11</sup>

**FIGURE 3.11. FPV installation (with a capacity of 3 MWp) Cheongpung Lake, Chungju Dam in Korea**



Source: © LSIS.

**FIGURE 3.12. Floating solar installation in Taiwan, China (a typhoon-prone area)**



Source: © Sungrow.

However, harsh weather conditions, such as typhoons, pose technical challenges for the implementation of FPV in the country, hence increasing system costs. Indeed, high wind speeds can destabilize and damage FPV systems, calling for additional stress testing of structural components (Kenning 2016a) (figure 3.12).

Many developers are looking to develop FPV projects in Taiwan, China. In partnership, Taiwan Power Co. and Taiwan Water Co. plan to install FPV systems on eight reservoirs in Chiayi County (Planair and PITCO 2017). New Green Power and J&V Holding have also announced a joint 20 MWp FPV project on an irrigation pond in Taoyuan County (Kenning 2017d).

In July 2018, the Ministry of Economic Affairs announced the development of a 320 MW special zone for solar power at the Changhua Coastal Industrial Park that would also feature FPV systems. Chenya Energy Co., Yeheng Energy, and a major subsidiary of Taiwan

Solar Energy Corp were awarded the right to build the special zone (Chia-erh 2018).

### **3.2.26. Thailand**

The Thai solar company SPCG announced that it would work with a Japanese renewable energy company, InterAct, to implement FPV in Thailand to power shrimp farms (Nikkei 2014). Also, Ciel & Terre International recently opened a new float manufacturing facility in Thailand with a maximum annual production of 50 MWp (Kenning 2017b). SCG Chemicals signed a memorandum of understanding with the main utility, Electricity Generating Authority of Thailand (EGAT), to work collaboratively in the research and development of a mooring system for an FPV farm on the utility's reservoirs and dams (SCG Chemicals 2018). SCG Chemicals has become Thailand's first company to successfully design and manufacture an FPV system; this has a 979 kWp capacity (All Around Plastics 2018) and is situated on an industrial pond at Rayong's Map Ta Phut Industrial Estate. EGAT recently announced it will facilitate the development of 2.7 GWp of hybrid floating solar-hydro projects across

11. Tariffs valid for the first half of 2019 and FX exchange rate as of January 31, 2019.

**FIGURE 3.13. FPV project on the Queen Elizabeth II Reservoir, United Kingdom**



Source: © Lightsource BP Floating Solar Array, London.

nine dams throughout the country. Two projects, of 45 and 24 MW respectively, are already in the development phase (Kenning 2018d).

### **3.2.27. Ukraine**

The UK-based asset manager Touchstone Capital Group Holdings Ltd. is looking at developing a hybrid 1.3 GWp wind-solar power project at the Kakhovka water reservoir, located on the Dnieper River, alongside the Kakhovka Hydroelectric Power Plant. It would comprise 1 GWp of wind and up to 300 MWp of FPV, with installations located between the wind turbines and anchored to their foundations (Bellini 2018c).

### **3.2.28. United Kingdom**

Limited space available for land-based PV and high on-site energy demand from water treatment plants are two key reasons for developing FPV in the United Kingdom. Several 100–200 kW FPV power plants have also been built on farms' irrigation reservoirs.

Europe's largest FPV project is located on the Queen Elizabeth II Reservoir run by Thames Water and funded, built, and operated by Lightsource BP and Ennoviga Solar (figure 3.13). It has a capacity of 6.3 MWp and was in 2016 one of the first FPV projects to be installed on a deep-water (18.4 meters) reservoir (Ciel & Terre International 2018). Ciel & Terre International designed the system and supplied the floating pontoons. Power generated by the site covers 20 percent of the water treatment facility's total energy demand (PV Tech 2018a).

The United Kingdom's second-largest FPV project is located at the Godley Reservoir in Hyde (Hill 2015). This 2.99 MWp project (a £3.5 million investment) developed by United Utilities was a bid to hedge a water treatment facility against increased power prices. It is able to provide 33 percent of the facility's electric energy requirements (Energy Matters 2015).

A start-up, AqvaFloat, is also launching a pontoon manufacturing facility in the United Kingdom with a capacity equivalent of 12 MWp (Parnell 2018).



**FIGURE 3.14.** FPV project in Orlando, Florida, United States



Source: © Ciel & Terre International.

### 3.2.29. United States

The world's first commercial FPV system of 175 kWp is since 2008 on an irrigation pond at the Far Niente Winery in Napa Valley, California. The pond and an adjacent land system are integrated, with 994 panels on the pond and 1,302 on land, covering 2.5 acres of space in total and producing more energy than the winery needs (Margaronis 2013).

A 4.4 MWp FPV system was completed in 2016 in Sayreville, New Jersey, and produces electricity for the Bordentown Avenue Water Treatment Plant. The Orlando Utilities Commission in Florida has also a strong interest in FPV. A 31.5 kW system was built in 2017 on one of its storm water storage reservoirs (figure 3.14) with the support of D3Energy and Ciel & Terre International (Pickerel 2017).

In the coming years, Sonoma Clean Power in California is building a 12.5 MWp project, contracting with San Francisco-based Pristine Sun to build solar systems to be mounted on docks across six wastewater ponds operated by the Sonoma County Water

Agency (Sonoma County Gazette 2015). Pristine Sun is leasing the ponds for about \$30,000 per year (Brown 2015).

Ciel & Terre International is also building four different FPV systems in the country, totaling 5.3 MW. One of them, a 252-kWp FPV system on a wastewater treatment pond in Kelseyville (California) was completed in September 2018 (Osborne 2018). A 75-kWp FPV system was recently installed by GRID Alternatives Colorado at the drinking water treatment facility of the town of Walden (Jackson County, Colorado) (Grid Alternatives 2018).

### 3.2.30. Vietnam

In a bid to encourage the large-scale implementation of renewable energy technologies, Vietnam's Ministry of Industry and Trade established a FIT scheme (Decision No. 11/2017/QĐ-TTg of the prime minister, passed on April 11, 2017 and taking effect from June 1, 2017) for utility-scale solar installations, that also applies to FPV projects. It was set to expire on June 30, 2019, but was extended in Ninh Thuan Province by

another 12 months (with a cap of 2 GWp). Grid-connected power plants are granted a FiT equivalent to about \$0.0935/kWh, not counting value added tax<sup>12</sup> (Baker McKenzie 2018). An updated policy on FiT is being drafted and should be finalized by June 2019 when the current FiT will expire.

Given the availability of freshwater bodies in Vietnam, and land constraints, there is ample room for the implementation of FPV systems. Many companies have announced plans to expand the country's FPV potential. For example, Vasari Energy, a California-based green tech company, is planning to develop

---

12. <https://www.lexology.com/library/detail.aspx?g=530843be-3857-4c97-a07d-e59db9a8a3a7>

two FPV projects in Vietnam, each with a capacity of 40–50 MWp (Kenning 2018c). In addition, Ciel & Terre International has opened a manufacturing facility in Vietnam (Kenning 2018c). A 47.5 MWp FPV project initiated by the Da Nhim-Ham Thuan-Da Mi Hydropower Joint Stock Company is under construction on the reservoir of its 175 MW Da Mi hydro power plant in Binh Thuan province, with the financial support of the Asian Development Bank (ADB 2018).

In 2017 the Korean company Solkiss announced its intention to develop a 500 MWp FPV plant in Yen Bai Province in southern Vietnam (Clover 2017a; 2017b).

---

## References

- ADB (Asian Development Bank). 2018. "Viet Nam: Floating Solar Energy Project." <https://www.adb.org/projects/51327-001/main#project-pds>.
- All Around Plastics. 2018. "Illuminating the Future—Sunlight and Innovation for Business Sustainability." *Innovation*, All Around Plastics, May 8. <http://www.allaroundplastics.com/en/article/innovation-en/1818>.
- Baker McKenzie. 2018. "Vietnam's Solar Feed-in-Tariff for Ninh Thuan Province Officially Extended for a Total Capacity of 2,000 MW." *Lexology*, September 12. <https://www.lexology.com/library/detail.aspx?g=530843be-3857-4c97-a07d-e59d-b9a8a3a7>
- Beetz, B. 2018. "Africa Announces Utility-Scale Floating Solar Tender." *PV Magazine*, April 9. <https://www.pv-magazine.com/2018/04/09/africa-announces-utility-scale-floating-solar-tender/>.
- Bellini, E. 2018a. "Colombia to Host Its First Floating PV Project." *PV Magazine*, April 19. <https://www.pv-magazine.com/2018/04/19/colombia-to-host-its-first-floating-pv-project/>.
- . 2018b. "Dutch Consortium Plans World's First 'Off-shore' Floating PV Plant for the North Sea." *PV Magazine*, February 7. <https://www.pv-magazine.com/2018/02/07/dutch-consortium-plans-worlds-first-off-shore-floating-pv-plant-for-the-north-sea/>.
- . 2018c. "Floating PV Goes Everywhere." *PV Magazine*, October 3. <https://www.pv-magazine.com/2018/10/03/floating-pv-goes-everywhere/>.
- . 2018d. "Belgium: Flemish Government to Support Pilot Floating Solar Projects with €6 Million." *PV Magazine*, April 3. <https://www.pv-magazine.com/2018/04/03/belgium-flemish-government-to-support-pilot-floating-solar-projects-with-e6-million/>.
- . 2018e. "Netherlands: Newly Created Consortium to Develop Floating PV." *PV Magazine*, January 11. <https://www.pv-magazine.com/2018/01/11/netherlands-newly-created-consortium-to-develop-floating-pv/>.
- . 2019. "Statkraft plans its first floating solar plant in Albania" *PV Magazine*, January 15. <https://www.pv-magazine.com/2019/01/15/statskraft-plans-its-first-floating-solar-plant-in-albania/>.
- Bernama. 2018. "TNB to Buy Solar-Generated Power from Two Perak-Based Facilities." *New Straits Times*, March 30. <https://www.nst.com.my/news/nation/2018/03/351151/tnb-buy-solar-generated-power-two-perak-based-facilities>.
- Bin, L. 2018. "China's Solar Industry Is at a Crossroads." *Chinadialogue*, August 13. <https://www.chinadialogue.net/article/show/single/en/10775-China-s-solar-industry-is-at-a-crossroads>.
- Brown, M. 2015. "Sonoma Clean Power Inks Deal for Floating Solar Panel Project." *The Press Democrat*, February 26. Accessed on March 9, 2018. <http://www.pressdemocrat.com/news/3580954-181/sonoma-clean-power-inks-deal>.
- Chi Lieu, D. 2018. "Vietnam Plans to Extend FiT Scheme for Solar Power Projects in Ninh Thuan Province until the End of 2020." *Lexology*, July 6. <https://www.lexology.com/library/detail.aspx?g=d2006854-8459-4a43-a2d1-34beb01e6e56>.
- Chia-erh, K. 2018. "Special Zone for Solar Power Set Up in Changhua." *Taipei Times*, July 18. <http://www.taipetimes.com/News/biz/archives/2018/07/18/2003696863>.
- Ciel and Terre. 2017. "Goias Farm—305 kWp—Floating Solar Power Plant in Brazil." <https://www.cieletterre.us/project/goias-farm-305-kwp-floating-solar-power-plant-brazil/>
- . 2018. "Our References: The Floating Solar Expert with Hydrelío Technology." <https://www.ciel-et-terre.net/wp-content/uploads/2018/07/CT-References-May-Jun.-2018.pdf>.
- Clover, I. 2017a. "South Korean Company Builds \$1.1b Floating Solar Plant in Vietnam." *Pakistan Defence*, March 27. Accessed March 9, 2018. <https://defence.pk/pdf/threads/south-korean-company-builds-1-1b-floating-solar-plant-in-vietnam.485941/>.

- . 2017b. "Vietnam Province Taps Korean Government for Assistance on 500 MW Solar Project." PV Magazine, March 27. <https://www.pv-magazine.com/2017/03/27/vietnam-province-taps-korean-government-for-assistance-on-500-mw-solar-project/>.
- . 2018. "South Korean State Energy Firm Plans 100 MW Floating PV Project." PV Magazine, February 12. <https://www.pv-magazine.com/2018/02/12/south-korean-state-energy-firm-plans-100-mw-floating-pv-project/>.
- Doo-soon, K., and L. Ha-yeon. 2018. "Hanwha Q Cells to Build Floating Solar Power Plant in Netherlands." Pulse, March 10. <https://pulsenews.co.kr/view.php?year=2018&no=228807>.
- Economic Development Board. 2018. "Request for Information: Large-Scale Floating Solar Photovoltaic System." Economic Development Board, Singapore, October 31. <https://www.edb.gov.sg/content/dam/edb/edbsite/news-and-resources/news/solar-pv-system/request-for-information-large-scale-floating-solar-pv-system-for-private-sector-consumption.pdf>.
- Energy Matters. 2015. "Huge Floating Solar Power System on UK Reservoir." Energy Matters, October 29. Accessed on March 9, 2018. <https://www.energymatters.com.au/renewable-news/floating-solar-uk-em5156/>.
- Eni.com. 2018. "Eni to Step up Cooperation in Renewable Energy in Ghana." Eni.com, February 13. [https://www.eni.com/en\\_IT/media/news/2018/02/eni-to-step-up-cooperation-in-renewable-energy-in-ghana#](https://www.eni.com/en_IT/media/news/2018/02/eni-to-step-up-cooperation-in-renewable-energy-in-ghana#).
- FAO (Food and Agriculture Organization). 2016. "AQUASTAT website." <http://www.fao.org/nr/water/aquastat/dams/index.stm>.
- Global Solar Atlas: <https://globalsolaratlas.info/>, World Bank Group (2019).
- Grid Alternatives. 2018. "Unveiling Colorado's First Floating Solar Array." Grid Alternatives, October 23. <https://gridalternatives.org/regions/colorado/news/unveiling-colorado%E2%80%99s-first-floating-solar-array>.
- Hill, J. S. 2015. "Construction Begins on Europe's Largest Floating Solar Plant." Clean Technica, October 28. Accessed on March 9, 2018. <https://cleantechnica.com/2015/10/28/construction-begins-europes-largest-floating-solar-plant/>.
- Islam, S. 2019. "Bangladesh prepares plans for two floating solar plants." PV Magazine, January 17. <https://www.pv-magazine.com/2019/01/17/bangladesh-prepares-plans-for-two-floating-solar-plants/>.
- Ji-woong, M., and C. Mira. 2018. "HHI Green Energy and KEPCO KPS Join Hands in Floating Solar Projects." Pulse, August 1. <https://pulsenews.co.kr/view.php?year=2018&no=483381>.
- Jonuzaj, K. 2018. "Albania's KESH seeks building permit for 12.9 MWp floating solar park." Renewables now, December 4. <https://renewablesnow.com/news/albanias-kesh-seeks-building-permit-for-129-mwp-floating-solar-park-635433>.
- Kabeer, N. 2018. "Shapoorji Pallonji Wins SECI's 50 MW Floating Solar Auction Quoting 3.29/kWh." Mercom India, November 27. <https://mercomindia.com/shapoorji-pallonji-wins-seci-50-mw-floating-solar-auction/>.
- Kenning, T. 2016a. "20GW by 2025: Behind Taiwan's Big Solar Numbers." PV Tech, November 2. Accessed on March 9, 2018. <https://www.pv-tech.org/features/20gw-by-2025-behind-taiwans-big-solar-numbers>.
- . 2017a. "Brazil's First Floating Solar Plant Completed by Ciel & Terre." PV Tech, September 6. <https://www.pv-tech.org/news/brazils-first-floating-solar-plant-completed-by-ciel-terre>.
- . 2017b. "Ciel & Terre to Launch Floating Solar Manufacturing in Thailand Next Year, Vietnam to Follow." PV Tech, November, 16. <https://www.pv-tech.org/news/ciel-terre-to-launch-floating-solar-manufacturing-in-thailand-next-year-vie>.
- . 2017c. "India's SECI Invites Expression of Interest for 10GW of Floating Solar." PV Tech, December 19. <https://www.pv-tech.org/news/indias-seci-invites-expression-of-interest-for-10gw-of-floating-solar>.
- . 2017d. "NGP to Build 14MW Floating Solar Plant in Taiwan." PV Tech, October 20. Accessed on March 9, 2018. <https://www.pv-tech.org/news/ngp-to-build-14mw-floating-solar-plant-in-taiwan>.
- . 2017e. "Sri Lanka to Tender 100MW Floating Solar Plant, Funds Module R&D." PV Tech, March 3. <https://www.pv-tech.org/news/sri-lanka-to-tender-100mw-floating-solar-plant-funds-module-rd>.
- . 2017f. "Sunseap and Linyang Energy Partner for 500MW Rooftop and Floating Solar in Singapore." PV Tech, December 12. <https://www.pv-tech.org/news/sunseap-and-linyang-energy-partner-for-500mw-rooftop-and-floating-solar-in>.



- . 2018a. "Akuo Energy Starts Construction on 17MW Floating Solar Plant in France." PV Tech, September 25. <https://www.pv-tech.org/news/akuo-energy-starts-construction-on-17mw-floating-solar-plant-in-france>.
- . 2018b. "Maharashtra Discom Consults on 1GW of Floating PV, Retenders 1GW of Solar." PV Tech, April 11. <https://www.pv-tech.org/news/maharashtra-discom-consults-on-1gw-of-floating-pv-retenders-1gw-of-solar>.
- . 2018c. "Vasari Plans 180MW of Ground-Mount and Floating Solar in Vietnam." PV Tech, January 22. Accessed on March 9, 2018. <https://www.pv-tech.org/news/vasari-plans-180mw-of-ground-mount-and-floating-solar-in-vietnam>.
- . 2018d. "Thailand utility eyes 1GW of floating solar on hydro dams, pilots energy storage" PV Tech, November 14. <https://www.pv-tech.org/news/thailand-utility-eyes-1gw-of-floating-solar-on-hydro-dams-pilots-energy-sto>.
- Lehner, B., C. Reidy Liermann, C. Revenga, C. Vörösmarty, B. Fekete, P. Crouzet, P. Döll, M. Endejan, K. Frenken, J. Magome, C. Nilsson, J.C. Robertson, R. Rodel, N. Sindorf, and D. Wisser. 2011a. "High-Resolution Mapping of the World's Reservoirs and Dams for Sustainable River-Flow Management." *Frontiers in Ecology and the Environment* 9 (9): 494–502.
- . 2011b. "Global Reservoir and Dam Database, Version 1 (GRanDv1): Dams, Revision 01." NASA Socioeconomic Data and Applications Center (SEDAC), Palisades, NY. <http://sedac.ciesin.columbia.edu/data/collection/grand-v1>.
- Margaronis, S. 2013. "Far Niente Winery's Floating Solar Experiment." RBTUS, October 19.
- MI News Network. 2017. "World's Largest Floating Solar Power Plant to Be Built in Japan." Marine Insight, January 19. Accessed on March 9, 2018. <https://www.marineinsight.com/shipping-news/worlds-largest-floating-solar-power-plant-to-be-built-in-japan/>.
- Ministry of Economic Affairs. 2018. "2018 Renewable Energy FIT Rates Are Announced." Bureau of Energy, Ministry of Economic Affairs, Taiwan, January 25. [https://www.moea.gov.tw/MNS/english/news/News.aspx?kind=6&menu\\_id=176&news\\_id=76457](https://www.moea.gov.tw/MNS/english/news/News.aspx?kind=6&menu_id=176&news_id=76457).
- National, The. 2018. "Japan's biggest floating solar plant sparks into life." April 3. <https://www.thenational.ae/business/energy/japan-s-biggest-floating-solar-plant-sparks-into-life-1.718330>.
- National Heritage Institute. 2017. "Sambor Hydropower Dam Alternatives Assessment." <https://n-h-i.org/programs/restoring-natural-functions-in-developed-river-basins/mekong-river-basin/cambodia-sambor/>.
- National Heritage Institute. 2018. "Sustainable Hydropower Master Plan for Xe Kong Basin in Lao PDR." <https://n-h-i.org/programs/restoring-natural-functions-in-developed-river-basins/mekong-river-basin/laos-xe-kong-2/>.
- Nikkei. 2014. "Floating Solar Panels to Cut CO2 at Thai Shrimp Farms." Asian Review-Nikkei, November 15.
- Office of the Cabinet of Ministers, Sri Lanka. 2016. "Making Use of the Mahaweli Economic Zones for the Development of Renewable Energy." Press briefing of Cabinet Decision taken on November 15, 2016. [http://www.cabinetoffice.gov.lk/cab/index.php?option=com\\_content&view=article&id=16&Itemid=49&lang=en&dID=7238](http://www.cabinetoffice.gov.lk/cab/index.php?option=com_content&view=article&id=16&Itemid=49&lang=en&dID=7238).
- Osborne, M. 2017a. "First Ever Hydro-Electric and Floating Solar Project Operating in Portugal." PV Tech, July 27. <https://www.pv-tech.org/news/first-ever-hydro-electric-and-floating-solar-project-operating-in-portugal>.
- . 2017b. "Floating Solar Pilot Projects in the Netherlands Set Sail." PV Tech, July 17. <https://www.pv-tech.org/news/floating-solar-pilot-projects-in-the-netherlands-disembark>.
- . 2018. "Ciel & Terre Building Four Floating Solar Projects in US." PV Tech, September 18. <https://www.pv-tech.org/news/ciel-terre-building-four-floating-solar-projects-in-us>.
- Panama Today. 2017. "Floating Solar Panels: A Panama Canal Green Project." Panama Today, November 25. <https://www.panamatoday.com/panama/floating-solar-panels-panama-canal-green-project-5836>.
- Parnell, J. 2018. "UK Start-Up Eyes Global Floating Solar Market." PV Tech, April 13. <https://www.pv-tech.org/news/uk-start-up-eyes-global-floating-solar-market>.
- Pickrel, K. 2017. "Trial floating solar installation in Orlando is first of hopefully many for Florida utility" Solar Power World, May 2. <https://www.solarpowerworldonline.com/2017/05/trial-floating-solar-installation-orlando-first-hopefully-many-florida-utility/>.
- Planair and PITCO. 2017. *Assessment of Floating Solar PV Potential for Pakistan; Task 1: Commercial Readiness of FSPV—*

- Global Market and Performance Analysis*. Unpublished report prepared for International Finance Corporation, Washington, DC..
- Prateek, S. 2018a. "Breaking: West Bengal Auctions 5 MW of Floating Solar PV." Mercom India, March 16. <https://mercomindia.com/west-bengal-auctions-5-mw-floating-solar-pv/>.
- . 2018b. "India's Largest 2 MW Floating Solar Project Commissioned in Greater Visakhapatnam." Mercom India, August 28. <https://mercomindia.com/india-largest-2mw-floating-solar-vishakhapatnam/>.
- . 2018c. "NTPC Tenders 22 MW of Grid-Connected Floating Solar Project in Kerala." Mercom India, June 25. <https://mercomindia.com/ntpc-tenders-22mw-floating-solar-kerala/>.
- . 2018d. "Uttar Pradesh Issues Tender for Development of 100 MW of Canal Top Solar PV Projects." Mercom India, June 7. <https://mercomindia.com/uttar-pradesh-tender-100mw-canal-top-solar-projects/>.
- PUB. 2017. "PUB Studying Clean Energy Solutions from Blue Spaces." Press release PUB, September 28. <https://www.pub.gov.sg/news/pressreleases/pubstudyingcleanenergysolutionsfrombluespaces>.
- . 2018. "PUB Looks to Bedok and Lower Seletar Reservoirs for More Solar Power." Press release, PUB, April 29. <https://www.pub.gov.sg/news/pressreleases/publookstobedokandlowerseletarreservoirsformoresolarpower>.
- Publicover, B. 2017a. "Korean Firm to Build 280 MW of Floating PV Capacity." PV Magazine, July 10. <https://www.pv-magazine.com/2017/07/10/korean-firm-to-build-280-mw-of-floating-pv-capacity/>.
- . 2017b. "Masdar to Build 200 MW Floating PV Array in Indonesia." PV Magazine, November 29. Accessed March 9, 2018. <https://www.pv-magazine.com/2017/11/29/masdar-to-build-200-mw-floating-pv-array-in-indonesia/>.
- PV Tech. 2018a. "Europe's Floating PV Pathfinder." PV Tech Power. PV Tech. p. 13.
- . 2018b. "Malaysia's First Grid-Connect Floating PV Project: A Matter of National Security." PV Tech Power. PV Tech. p. 12, 13.
- . 2018c. "ROUND-UP: Colombia's 'First' Floating Plant, Iran's Khorasan Gets 10MW, Clenergy East Asia Orders." <https://www.pv-tech.org/news/round-up-colombias-first-floating-plant-irans-khorasan-gets-10mw-clenergy-e>.
- Quirke, J. 2017. "South Korea to Build World's Largest Rotating Floating Solar Plant." Global Construction Review, July 12. <http://www.globalconstructionreview.com/news/south-korea-build-worlds-largest-rotating-floating/>.
- Rambu Energy. 2017. "Indonesia to Have Its First and Largest Floating Solar Power by 2019." Rambu Energy, December 2. <https://www.rambuenergy.com/2017/12/indonesia-to-have-its-first-and-largest-floating-solar-power-by-2019/>.
- Rao, U. 2018. "GVMC to Set up 15 MW Floating Solar Project on Meghadrigedda." Times of India, October 24. <https://timesofindia.indiatimes.com/city/visakhapatnam/gvmc-to-set-up-15-mw-floating-solar-project-on-meghadrigedda/article-show/66354338.cms>.
- ReNew Power. 2018. "ReNew Power Wins 3 MW Floating Solar PV Project at Visakhapatnam." ReNew Power, October 18. <https://renewpower.in/wp-content/uploads/2018/10/ReNew-Power-Wins-3-MW-Floating-Solar-PV-Project-at-Visakhapatnam.pdf>.
- Reve. 2015. "Potential for Floating Photovoltaic Solar Energy in Malaysia." Reve, June 4. Accessed on March 6, 2018. <https://www.evwind.es/2015/06/04/potential-for-floating-photovoltaic-solar-energy-in-malaysia/52537>.
- Saurabh. 2016. "Indian Hydro Power Company Plans 600 MW Floating Solar Power Project."
- SCG Chemicals. 2018. "SCG Joins Hands with EGAT to Develop Floating Solar Farm's Mooring System for Power Generation." Press release, July 25. <https://www.scgchemicals.com/en/news-media/news-events/press-release/detail/431>.
- Scotra. 2018. "It Is the Case of a SCOTRA Floating PV System Installed." Scotra, June 22. [http://scotra.co.kr/bbs/board.php?bo\\_table=en\\_case01&wr\\_id=63](http://scotra.co.kr/bbs/board.php?bo_table=en_case01&wr_id=63).
- Sivakumar, B. 2019. "Tangedco aims for 250MW solar floating projects." The Economic Times, January 25. <https://energy.economictimes.indiatimes.com/news/renewable/tangedco-aims-for-250mw-solar-floating-projects/67682064>.

- Sonoma County Gazette. 2015. "S Sonoma Clean Power Contracts to Build Largest US Floating Solar Project." Sonoma County Gazette, February 27. <https://www.sonomacountygazette.com/cms/pages/sonoma-county-news-article-3597.html>.
- Sun Daily, The. 2018. "Sarawak CM Suggests LONGi Group to Develop Floating Solar Park." The Sun Daily, April 16. <http://www.thesundaily.my/news/2018/04/16/sarawak-cm-suggests-longi-group-develop-floating-solar-park>.
- Sungrow. N.d. "1.2+1.9MW Floating PV Power Plant Project in Tainan City, Taiwan." [https://en.sungrowpower.com/reference?id=22&ref\\_cate\\_id=30](https://en.sungrowpower.com/reference?id=22&ref_cate_id=30).
- Tan, A. 2018. "HDB Exploring Floating Solar Panels in Open Sea." The Straits Times, July 9. <https://www.straitstimes.com/singapore/environment/hdb-exploring-floating-solar-panels-in-open-sea>.
- Tsanova, T. 2018. "Dutch PWN Launches 7-MWp Floating Solar Tender." Renewables Now, September 17. <https://renewablesnow.com/news/dutch-pwn-launches-7-mwp-floating-solar-tender-626921/>.
- Vientiane Times. 2018. "Japanese Firm to Build 14MW Floating Solar Power Farm in Hadxaifong." *Vientiane Times*, Asia News Network, June 21. <http://asianews.eu/content/japanese-firm-build-14mw-floating-solar-power-farm-hadxai-fong-75282>.
- Yonhap News Agency. 2018. "S. Korea to Create Floating Solar Farm on Sihwa Lake." Yonhap News Agency, September 4. <http://english.yonhapnews.co.kr/news/2018/09/04/0200000000AEN20180904001600320.html>.
- Zaripova, A. 2016. "Brazil Launches First Stage of 10 MW Floating PV System." PV Magazine, March 7. [https://www.pv-magazine.com/2016/03/07/brazil-launches-first-stage-of-10-mw-floating-pv-system\\_100023576/](https://www.pv-magazine.com/2016/03/07/brazil-launches-first-stage-of-10-mw-floating-pv-system_100023576/).

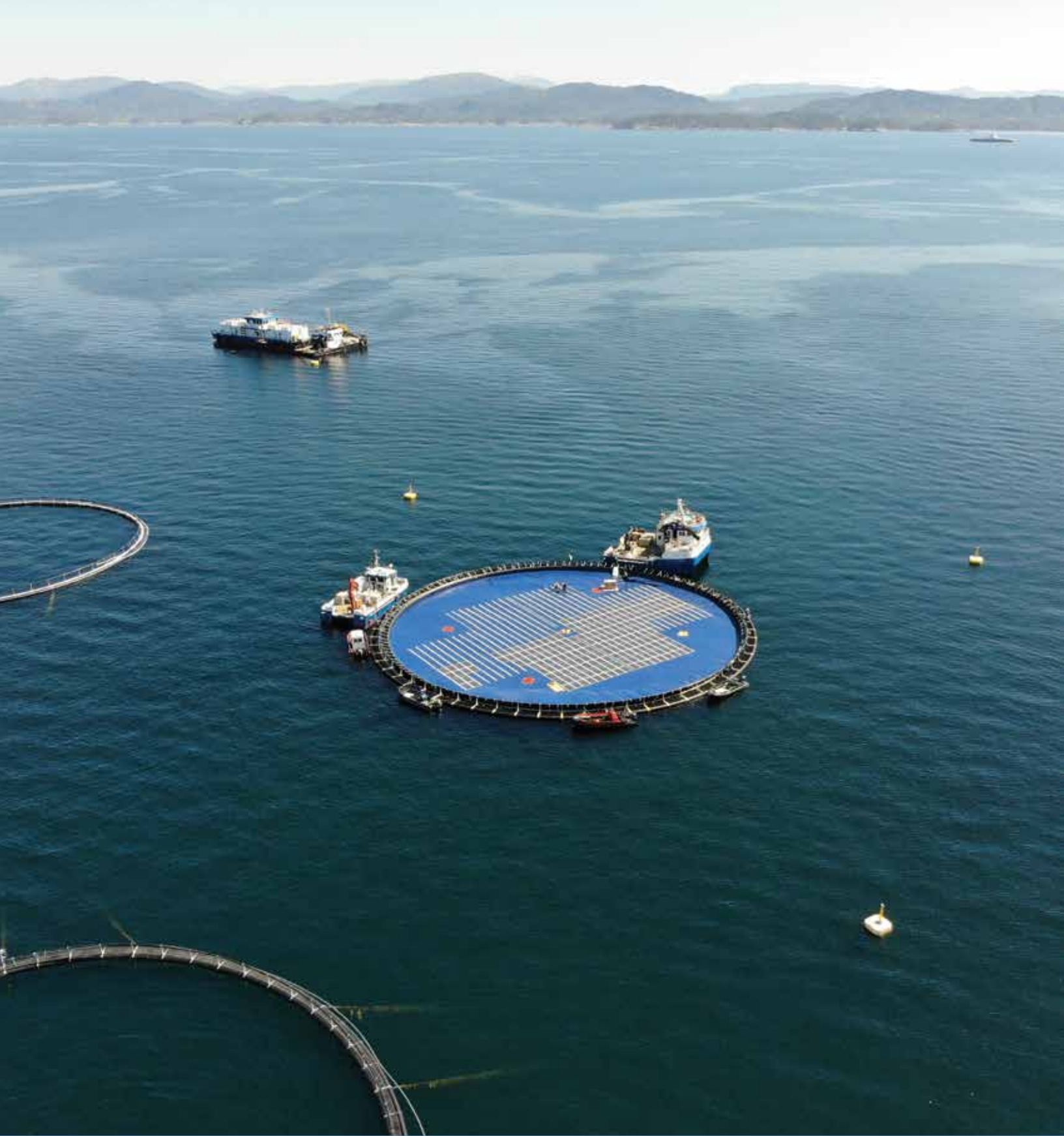

NORWAY

© Ocean Sun



# 4 POLICY CONSIDERATIONS AND PROJECT STRUCTURING

As highlighted in this report, deployment of floating solar photovoltaic (FPV) power is cost-competitive under many circumstances and therefore should not require financial support. Nevertheless, initial projects may require some form of support to overcome barriers associated with the industry's relatively limited experience with FPV technology.

Countries have taken various approaches to FPV power. Many of the policies supporting FPV installations fall into one of two categories: (i) financial incentives or (ii) supportive governmental policies. These are discussed in the sections that follow.

## 4.1 Financial incentives and support mechanisms in selected countries

Few countries have provided financial incentives specifically for FPV systems. However, most countries that are still implementing preferential feed-in tariffs (FiTs) for solar PV typically also include FPV. This is the case in Japan, Malaysia, and Vietnam, among others.

In a bid to encourage the large-scale implementation of renewable energy technologies, Vietnam's Ministry of Industry and Trade (MOIT) established a FiT scheme for all on-grid utility-scale solar installations in 2017; it also applies to FPV projects.<sup>13</sup> Set to expire on June 30, 2019, the scheme was extended for another 12 months in Ninh Thuan province, but with a 2 GW capac-

ity ceiling.<sup>14</sup> Grid-connected power plants are granted a FiT equivalent to \$0.0935/kWh, before value added tax. On 29 January 2019, MOIT released a first draft update of the country's current feed-in tariff structure. The draft FiTs will vary based on (i) the completion date, (ii) location, and (iii) type of solar projects (i.e., floating, ground-mounted, integrated storage system or rooftop solar). In the latest draft, released on 12 April 2019, the new FiT for floating solar projects will be 8.5% higher than for ground-mounted PV, but is still subject to potential changes.<sup>15</sup>

In Malaysia, a FiT in force since 2011 has pre-set capacity ceilings for each technology. The so-called "RE quota" administered by the Sustainable Energy Development Authority<sup>16</sup> is set every six months and covers a period of three years. However, there is currently no quota available for FPV projects. Large-scale solar PV (including FPV) projects are implemented via auctions, as discussed in section 4.2.3.

In Japan, large-scale PV solar systems were eligible for a FiT until 2017, when systems of 2 MWp and above (including FPV) became ineligible. Offtake prices are now determined through a competitive auction system.

Some economies have specific FPV support mechanisms. Examples are Taiwan, China; the state of Massachusetts in the United States; and the Republic of Korea (table 4.1).

13. Prime Minister's Decision No. 11/2017/QĐ-TTg, passed on April 11, 2017, and taking effect in June 2017.

14. Resolution No. 115, dated August 8, 2018; <https://www.lexology.com/library/detail.aspx?g=530843be-3857-4c97-a07d-e59db9a8a3a7>

15. <https://www.bakermckenzie.com/en/insight/publications/2019/04/updated-draft-policy-on-feed>

16. <http://www.seda.gov.my/>

**TABLE 4.1. Examples of financial support mechanisms for FPV systems, 2018**

Economy	Support mechanism
Taiwan, China	In Taiwan, China, a specific feed-in tariff applies to floating solar photovoltaic (FPV) power; it is higher than the FiT for ground-mounted photovoltaic systems. In the second half of 2018, the FiT for ground-mounted systems was NT\$4.2943/kWh as opposed to NT\$4.6901/kWh for FPV systems. In early 2019, the Ministry of Economic Affairs announced that the FiTs for FPV would be reduced in the first half of 2019 to NT\$4.5016/kWh (for projects not connected to the high-voltage transmission grid) or NT\$4.9345/kWh (for connected projects). These tariffs are about 10 percent higher than the FiTs for similar-size ( $\geq 1$ MW) ground-mounted PV projects. FPV FiTs will drop by another 1.5 percent in the second half of 2019 <sup>a</sup> (Ministry of Economic Affairs 2018–2019).
Massachusetts, United States	The Solar Massachusetts Renewable Target (SMART) Program was implemented in 2018. It offers a location-based compensation rate add-on of \$0.03/kWh (Tranche I—80 MW) for FPV under certain conditions (Mass.gov n.d.).
Korea, Rep.	As part of the Renewable Portfolio Standards, power producers with installed generation capacity greater than 500 MW must produce a minimum proportion of their power using new and renewable energy sources. The 2018 obligatory renewable service supply ratio is 6 percent of total power generation (excluding new and renewable energy generation). A weighting scheme is applied to various renewable technologies for purposes of computing the ratio. A weighting of 1.5 applies to FPV installations, as opposed to 0.7 for land-based systems larger than 3 MW (Korea Energy Agency n.d.).

Source: Authors' compilation based on sources mentioned in table.

Note: FPV = floating photovoltaic; kWh = kilowatt-hour; MW = megawatt; NT\$ = New Taiwan dollar.

a. [https://www.moea.gov.tw/MNS/populace/news/News.aspx?kind=1&menu\\_id=40&news\\_id=82734](https://www.moea.gov.tw/MNS/populace/news/News.aspx?kind=1&menu_id=40&news_id=82734).

## 4.2 Supportive governmental policies

Governmental policies favoring clean energy—such as ambitious renewable energy targets, construction of pilot FPV plants, and solar PV tenders and auctions—have helped FPV projects come to fruition in certain countries.

### 4.2.1 Renewable energy targets

Most of the world's countries have renewable energy targets, some of which are very ambitious (table 4.2). In locations where population density is high, and land is scarce or has a high opportunity cost, FPV may have a key role to play in reaching these ambitious targets.

### 4.2.2 Pilot plants

Dedicated agencies of some governments have supported the set-up of demonstration or pilot plants. India, the Netherlands, and Singapore are examples.

The first pilot project in India, funded by the Ministry of New and Renewable Energy, became operational in 2014. Following its success, other institutions and government bodies began considering installing small demonstration projects across the country. Numerous FPV tenders were launched in 2018, and more than 1.8 GWp of capacity is either planned, tendered, or under construction.

After more than two years of analyzing the operating results of the world's largest FPV testbed in Singapore, the country's Economic Development Board (EDB), in late 2018, commenced the first phase of a commercial tender to build 100 MWp of FPV atop a reservoir, with more projects in the pipeline on other reservoirs.

In the Netherlands, the national consortium Zon op Water was created in 2017 at the initiative of the Ministry of Infrastructure and Water Management. Its ambitious aim is to promote the development and installation of 2 GWp of FPV in the Netherlands by 2023. Multiple demonstration plants are being implemented to test FPV in various environments.

**TABLE 4.2. Selected ambitious solar PV targets**

Country	Target	By Year	Source
China	210-270 GWp solar PV	2020	<a href="https://www.pv-magazine.com/2018/11/05/china-may-raise-2020-solar-target-to-over-200-gw/">https://www.pv-magazine.com/2018/11/05/china-may-raise-2020-solar-target-to-over-200-gw/</a>
India	100 GWp solar PV	2022	<a href="https://www.greentechmedia.com/articles/read/woodmac-expects-india-to-miss-2022-renewables-target#gs.NOv-VS8ym">https://www.greentechmedia.com/articles/read/woodmac-expects-india-to-miss-2022-renewables-target#gs.NOv-VS8ym</a>
Japan	64 GWp solar PV	2030	<a href="https://www.pv-magazine.com/2017/12/12/japan-may-surpass-2030-pv-target-of-64-gw-within-two-years-rt/">https://www.pv-magazine.com/2017/12/12/japan-may-surpass-2030-pv-target-of-64-gw-within-two-years-rt/</a>
Korea, Rep.	30 GWp solar PV	2030	<a href="https://www.pv-magazine.com/2017/12/20/solar-installations-to-soar-under-new-south-korean-energy-plan/">https://www.pv-magazine.com/2017/12/20/solar-installations-to-soar-under-new-south-korean-energy-plan/</a>
Taiwan, China	20 GWp solar PV	2025	<a href="https://www.pv-magazine.com/2018/12/12/obscured-policies-in-taiwans-fit-scheme-to-impact-on-sustainable-development-of-local-solar-supply-chain/">https://www.pv-magazine.com/2018/12/12/obscured-policies-in-taiwans-fit-scheme-to-impact-on-sustainable-development-of-local-solar-supply-chain/</a>

Source: Authors' compilation based on sources mentioned in table.

Other pilot plants (led by either the private or public sector) are being considered in Afghanistan, Albania, Azerbaijan, Kyrgyz Republic, Liberia, the Philippines, Thailand, and the United States, to name just a few countries.

### 4.2.3 Tenders and auctions

In 2016, as part of its so-called Top Runner program, China's National Energy Agency issued a tender for the installation of 1 GWp of FPV in coal-mine subsidence areas, mainly in Anhui Province. An additional 400 MWp was tendered in Shandong Province. As reported in chapter 3, the winning bidders (among them Sungrow, Trina, GCL, Xinyi, CECEP, and China Three Gorges New Energy) sell the generated electricity to the State Grid Corporation of China at rates ranging from yuan (Y) 0.71 to Y 0.81 per kilowatt-hour (kWh) (\$0.11–0.12/kWh).

Producing solar power in mining regions while scaling back coal-based power production is one way to address local air pollution in several regions of China (Mason and BBC, 2018). There are dozens of flooded coal mines in China. Spurred by the so-called Top Runner program, solar developers are turning these environmental and social challenges into an opportunity. Anhui Province is home to the world's largest FPV installations to date, ranging from 20 MWp to 150 MWp per site. Local people who just a few years ago worked underground as coal miners are now being retrained

as solar panel assemblers and maintenance personnel. They are earning better wages and are no longer exposed to harmful mine conditions known to cause lung disease.

As shown in figure 4.1, the 150 MWp FPV project built by Sungrow in Anhui Province is located at a subsidence area in Guqiao town, which covers an area of 422 hectares. It is estimated that the project will reduce annual average standard coal consumption by 62,900 tons and reduce annual carbon dioxide emission by 150,000 tons (Sungrow 2019).

In India, many solar PV tenders are organized by the Solar Energy Corporation of India or other utilities and distribution companies facing stringent renewable purchase obligations mandated by central and state governments. These tenders are for specific FPV projects to be built on pre-determined reservoirs in the states of Andhra Pradesh, Himachal Pradesh, Kerala, Maharashtra, Rajasthan, Telangana, Uttar Pradesh, and West Bengal, among others. More specifically, following new regulations from the central government, the thermal power generation company, NTPC Ltd, has launched several tenders for FPV projects as components of a series of renewable power plants built at existing power stations to meet renewable generation obligations. Building FPV projects at existing conventional power plants brings the additional advantage of allowing distribution companies to meet their renew-

**FIGURE 4.1.** Coal mine subsidence area in Anhui Province, China, rehabilitated with Sungrow Guqiao 150 MWp FPV system. Left: after construction of FPV system; right: local people employed by Sungrow



Source: © Sungrow.



Source: © Sungrow.

able purchase obligations through existing power purchase agreements.<sup>17</sup>

Under France's large-scale solar PV auction scheme, the Ministry of Ecological and Solidarity Transition in 2017 tendered 70 MWp of innovative solar capacity. Among the winning bidders were several small-scale FPV projects.

In Malaysia, two Large-Scale Solar tenders (LSS1 and LSS2) have been completed with a total awarded installed capacity of 958 MWp. Four projects from LSS2, totaling about 80 MWp have been attributed to FPV projects. The LSS is an initiative from the government to achieve Malaysia's national renewable energy roadmap. Past tenders included an additional merit point in the comparative price of bid calculation to encourage use of former mine lands, and which have benefited FPV projects foreseen on flooded collapsed mines, like in China. A new 500 MWp Large Scale Solar 3 (LSS3) scheme was tendered in early 2019. An open tender, it is expected to include FPV projects, as it includes the same merit point mechanism as for previous tenders.

Receptivity of the entities responsible for managing water bodies will be essential if FPV's broader potential

is to be unlocked. Positive examples include tenders for water-lease contracts in Korea with K-Water, in Singapore with PUB, and in the Netherlands with NV PWN Waterleidingbedrijf Noord-Holland.

### 4.3 Other policy and regulatory considerations

Even countries in which FPV power has undergone significant development lack clear, specific regulations on permitting and licensing of such plants. To a great extent, regulatory processes can be based on those employed for ground-mounted PV, but legal interpretation is still needed. In some countries, reservoirs for drinking water and hydropower plants are considered national-security sites, making permitting more complex and potentially protracted.

For most countries hoping to develop a well-functioning FPV segment as part of their solar PV market development, key policy and regulatory considerations remain to be addressed. These include:

- Unique aspects of permitting and licensing that necessitate interagency cooperation between energy and water authorities. This also includes environmental impact assessments for FPV installations.

<sup>17</sup><https://www.financialexpress.com/industry/ntpc-invites-1000-mw-renewable-energy-tenders/1396219/>



- Water rights and permits to install and operate an FPV plant on the surface of a water body and anchor it in or next to the reservoir.
- Tariff setting for FPV installations, which could be done as for land-based PV, for example, through FITs for small installations and tenders or auctions for large projects.

Other questions pertain to access to existing transmission infrastructure. How will this be managed? Who will be responsible? What permits and agreements will be required?

Hydro-connected plants call for special consideration. Will the owner/operator of the hydropower plant be allowed to add an FPV installation? Will it be permitted to offer a concession to a third party to build, own, and operate such an installation? If so, rules must be devised to coordinate dispatch of the solar and hydropower plants' output. Finally, risks and liabilities related to the hydropower plant may also affect connected solar facilities.

#### 4.4 Business models and project structuring

As of end 2018, the largest completed FPV projects are located in China (up to 150 MWp). Other large projects are located in Korea (up to 18.7 MWp) and Japan (up to 13.7 MWp). Most other FPV systems are much smaller in scale (i.e., typically around 5 MWp or less), though this is expected to change soon, as many utility-scale projects are under development around the world.

The business model and type of financing of an FPV project will depend on its size and offtake arrangement. Many models are appropriate; most are similar to those used for ground-mounted and rooftop PV installations.

Either the electricity produced can be self-consumed or it can be sold to a local or national power utility. Which of the options is chosen depends on national regulations (e.g., net metering), existing FITs for PV,

and whether there is an energy-intensive user close to the FPV system (e.g., a water treatment facility).<sup>18</sup> In Japan and China, most FPV-generated electricity is sold to the grid, whereas in the United Kingdom most FPV plants produce for self-consumption, and only surplus is injected into the grid. Some examples are given below:

- **Japan.** Because the FIT for solar energy is high, FPV plants usually sell their generated solar electricity to the grid. However, because systems larger than 2 MWp no longer benefit from a FIT (as of 2017), a shift toward self-consumption could become more common.
- **United Kingdom (Queen Elizabeth II and Godley).** The two largest FPV plants in the United Kingdom both sell electricity (behind the meter) to a local water treatment facility. The surplus is then injected into the grid. Both plants were realized under the United Kingdom's Renewable Obligation scheme.
- **China (Anhui Province).** Most of China's megawatt-scale FPV plants are being built under the so-called Top Runner program. All generated electricity is sold to local electricity companies at a tariff determined through competitive bidding.<sup>19</sup>

To understand how FPV projects are typically financed, it is useful to divide them into two groups: those whose installed capacity is less than or equal to 5 MWp, and those whose installed capacity is greater than 5 MWp. Table 4.3 summarizes typical financial structures for these two classes, which are similar to those for land-based PV deployment. To build trust in the technology, public grants are often provided to finance research and development and pilot projects (<1 MWp) that could be run by companies (as in the case of the Top Runner program projects in China) or by universities and public research institutions (as in the case of Singapore's testbed).

18. "Task 1: Commercial Readiness of FSPV—Global Market and Performance Analysis," in Planair and PITCO (2017).

19. Ibid.

**TABLE 4.3. Typical financing structures of FPV systems**

System size (MWp)	Business model	Ownership	Financing structure
≤ 5	Self-consumption (with excess sold to the grid where possible)	Commercial and industrial companies	Pure equity or mix of equity and corporate financing (or “balance sheet” financing). Owner would typically be an energy-intensive commercial or industrial company with ponds, lakes, or reservoirs on its premises and willing to install a floating solar system for its own use. In this case, the project owner (a developer; engineering, procurement, and construction contractor; or a corporate consumer) funds the project by borrowing against the company’s balance sheet. Vendor financing is also possible in cases where one of the equipment manufacturers (e.g., the module or float structure supplier) is an established company with a strong balance sheet.
> 5	Power sold to the grid through a power purchase agreement	Independent power producers and public utilities	Mix of debt and equity (typically 80:20); on balance sheet or nonrecourse project finance. Projects larger than 10 MWp will likely use project finance structures similar to those of utility-scale ground-mounted photovoltaic projects.

Source: Authors’ compilation.

Note: MWp = megawatt-peak.

Except in China, most FPV projects are small and financed in local currencies by local or regional banks. In Japan and Taiwan, China, local commercial banks have taken advantage of the favorable long-term FiTs available for FPV. Large international commercial banks as well as multilateral development finance institutions are expected to get involved as larger projects start to be developed in low-income countries.

Given their many advantages, projects that combine FPV with hydropower are likely to proliferate. New financing structures could enable FPV systems to be built on the reservoirs of hydropower plants by offering the lenders financing the FPV system recourse to a share of the cash flows of the hydropower plant.

Table 4.4 outlines a few examples of financing structures and business models used in FPV systems. In the Netherlands, a bank’s ability to identify appropriate security is a major challenge to implementing FPV projects. To ensure that the FPV system is not considered

as a part of the water surface owned by another party via the Dutch legal concept of accession (*natrekking*), the owner of the FPV system must receive a right of superficies (*opstalrecht*). According to the Dutch Civil Code (Article 5:101 [1] DCC), a right of superficies enables its proprietor—the “superficiary”—to have or acquire for himself buildings, constructions, or plants (vegetation) in, on, or above an immovable thing owned by someone else. This means that under Dutch civil law, the owner of an FPV system (e.g., the asset owner) could be different from the owner of the water surface (e.g., the public water utility). By obtaining a right of superficies, the developer of the FPV system can avoid the risk of accession. The bank will usually require a mortgage on this right of superficies. It is therefore important to understand the property rights and rights of ownership of movable and immovable assets applicable in the jurisdiction where an FPV system is being built, as these may affect the lenders’ options to request or enforce security interests in the project.

**TABLE 4.4. Selected business models and project finance structures used for FPV structures**

Country	Project	Status	Observations
United Kingdom	6.3 MWp Queen Elizabeth II floating photovoltaic (FPV) system	Operational	The London's Queen Elizabeth II FPV project, which cost about £6.5 million, was funded, installed, and operated by Lightsource BP. The floating array covers less than 10 percent of the reservoir's surface. The project generates about 5,750 megawatt-hours (MWh) of power per year and sells it to Thames Water, the United Kingdom's largest water and wastewater company, via a private-wire power purchase agreement with Lightsource BP. The FPV system satisfies around 20 percent of Thames Water's energy needs, as part of the utility's ambitious bid to self-generate a third of its own energy by 2020 (Lightsourcebp 2016).
Netherlands	1.8 megawatt-peak (MWp) Lingewaard FPV system (Gelderland)	Operational	Tenten Solar Zonnepanelen B.V. has developed the project for Drijvend Zonnepark Lingewaard B.V. under the SDE+ scheme of governmental subsidies in the Netherlands (Netherlands Enterprise Agency n.d.). The project was financed through a nonrecourse project finance loan from ING.
France	17 MWp O'MEGA 1 FPV system	Under construction	The project is located in Piolenc, Vaucluse, and developed by Akuo Energy. It is the first in France to use nonrecourse financing, with a loan of €12.8 million from Natixis Energieco. The project has a mixed ownership structure with capital from the local municipality, Akuo Solar, and residents (via crowdfunding) (Kenning 2018). Akuo Solar holds 60 percent of the shares while the municipality and residents hold 40 percent. The debt-equity ratio is 73:27, and the loan structure is similar to that of ground-mounted PV projects.
Vietnam	47.5 MWp DHD FPV System at Da Mi	Under construction	DHD is expected to enter a 20-year PPA with EVN under the current feed-in tariff regime of \$0.0935/kilowatt-hour equivalent, paid in Vietnamese dong but indexed to the U.S. dollar. The Asian Development Bank has proposed to provide a direct loan of up to \$20 million as well as concessionary loans up to \$22 million (from various sources). All loans will have a tenure of up to 15 years, including a 1-year grace period on the principal repayment. The bank can also rely on DHD's 722 MW of existing hydropower as a financial backstop (ADB 2018).

Source: Authors' compilation.

---

## References

- ADB (Asian Development Bank). 2018. "Project Number: 51327-001: Report and Recommendation of the President to the Board of Directors." Manila. September. <https://www.adb.org/sites/default/files/project-documents/51327/51327-001-rrp-en.pdf>
- Baker McKenzie, September 12 2018: "Vietnam's solar feed-in-tariff for Ninh Thuan Province officially extended for a total capacity of 2,000 MW." <https://www.lexology.com/library/detail.aspx?g=530843be-3857-4c97-a07d-e59db9a8a3a7>
- BBC (British Broadcasting Corporation). 2018. "Solar Farm Means 'I Can Breathe More Easily.'" Video story, BBC News, April 24. <https://www.bbc.co.uk/news/av/business-43881280/solar-farm-means-i-can-breathe-more-easily>.
- Decision No. 11/2017/QĐ-TTg of the Prime Minister dated 11 April 2017, Vietnam. <http://www.lse.ac.uk/GranthamInstitute/wp-content/uploads/laws/8277.pdf>
- Duane Morris LLP, February 1 2019 : "Vietnam's draft new solar tariffs—more sun, less cents, more sense." [https://www.lexology.com/library/detail.aspx?g=93915ecf-4410-4246-8260-ef7d81d0a0f6&utm\\_source=lexology+daily+news-feed&utm\\_medium=html+email+-+body+-+general+section&utm\\_campaign=lexology+subscriber+daily+feed&utm\\_content=lexology+daily+newsfeed+2019-02-04&utm\\_term=](https://www.lexology.com/library/detail.aspx?g=93915ecf-4410-4246-8260-ef7d81d0a0f6&utm_source=lexology+daily+news-feed&utm_medium=html+email+-+body+-+general+section&utm_campaign=lexology+subscriber+daily+feed&utm_content=lexology+daily+newsfeed+2019-02-04&utm_term=)
- Dutch Civil Code, Article 5:101 [1].
- Korea Energy Agency. N.d. "Renewable Portfolio Standards." [http://www.energy.or.kr/renew\\_eng/new/standards.aspx](http://www.energy.or.kr/renew_eng/new/standards.aspx).
- Mason, Pauline. 2018. "Meet the Ex-Miners Who Are Now Walking on Water." BBC News, April 27. <https://www.bbc.co.uk/news/business-43864665>.
- Mass.gov. N.d. "Solar Massachusetts Renewable Target (SMART) Program: General Information." <https://www.mass.gov/info-details/solar-massachusetts-renewable-target-smart-program#general-information->.
- Ministry of Economic Affairs. 2018. "2018 Renewable Energy FIT Rates Are Announced." Bureau of Energy, Ministry of Economic Affairs, January 25. [https://www.moea.gov.tw/MNS/english/news/News.aspx?kind=6&menu\\_id=176&news\\_id=76457](https://www.moea.gov.tw/MNS/english/news/News.aspx?kind=6&menu_id=176&news_id=76457).
- Ministry of Economic Affairs. 2019. "附表一、108 年度太陽光電公告費率." Bureau of Energy, Ministry of Economic Affairs, January 30. [https://www.moea.gov.tw/MNS/populace/news/News.aspx?kind=1&menu\\_id=40&news\\_id=82734](https://www.moea.gov.tw/MNS/populace/news/News.aspx?kind=1&menu_id=40&news_id=82734).
- Planair and PITCO. 2017. *Assessment of Floating Solar PV Potential for Pakistan; Task 1: Commercial Readiness of FSPV—Global Market and Performance Analysis*. Unpublished report prepared for International Finance Corporation, Washington, DC.
- Government of Vietnam. 2018. "Resolution No. 115/NQ-CP." August 31. Hanoi. [http://vepg.vn/wp-content/uploads/2018/10/115\\_NQ-CP\\_310818\\_CP\\_Dev-of-Ninh-Thuan\\_EN\\_GIZ-unofficial-transl.pdf](http://vepg.vn/wp-content/uploads/2018/10/115_NQ-CP_310818_CP_Dev-of-Ninh-Thuan_EN_GIZ-unofficial-transl.pdf)

### Press articles and other sources

#### Press articles

- <https://www.pv-magazine.com/2018/12/12/obscured-policies-in-taiwans-fit-scheme-to-impact-on-sustainable-development-of-local-solar-supply-chain/>
- <https://www.pv-magazine.com/2018/11/05/china-may-raise-2020-solar-target-to-over-200-gw/>
- <https://www.greentechmedia.com/articles/read/woodmac-expects-india-to-miss-2022-renewables-target#gs.NOvVS8ym>
- <https://www.pv-magazine.com/2017/12/12/japan-may-surpass-2030-pv-target-of-64-gw-within-two-years-rtts/>
- <https://www.pv-magazine.com/2017/12/20/solar-installations-to-soar-under-new-south-korean-energy-plan/>
- <https://www.pv-magazine.com/2018/12/12/obscured-policies-in-taiwans-fit-scheme-to-impact-on-sustainable-development-of-local-solar-supply-chain/>



<https://www.financialexpress.com/industry/nptc-invites-1000-mw-renewable-energy-tenders/1396219/>

<https://www.pv-tech.org/news/akuo-energy-starts-construction-on-17mw-floating-solar-plant-in-france>

#### **Other sources**

<https://www.lightsourcebp.com/uk/stories/qe2/>

<https://english.rvo.nl/subsidies-programmes/sde>

<http://www.seda.gov.my/>



# 5 COSTS OF FLOATING SOLAR

In this chapter, the theoretical costs of floating and ground-mounted photovoltaic (PV) systems are compared, using average figures based on industry feedback and publicly available data. Since floating PV (FPV) systems are not as common or widespread as ground-mounted systems, it remains difficult to have data about their capital and operating costs that could be generalized. The analysis presented here uses reasonable assumptions based on information available in the public domain and best practices from the industry. A more detailed analysis would need to be performed at a country level, and of course on a project basis, for a complete picture of how FPV compares to ground-mounted in given circumstances.

It should be clarified here, at the outset, that even though the two are being compared, FPV is not being put forward as a competitor to ground-mounted projects. Floating installations are complementary to ground-mounted systems and serve different needs and purposes. For example, when integrated with hydropower plants, they can help reduce the seasonal variability of hydropower generation. Or they can be used to harness the sun's energy even where land is expensive or scarce, or to help commercial and industrial companies garner profits from large, unused water bodies on their premises—and benefit from supply of additional electricity. Many business models exist; the best choice depends on the context, including the policy and regulatory framework.

## 5.1 Recent disclosed FPV costs

To start, we will consider the publicly announced turn-key engineering, procurement, and construction (EPC) costs of projects using similar types of technology (i.e.,

a float structure made of high-density polyethylene, HDPE). Total project costs are not always accurately disclosed in the public domain and should be taken as indicative, as it is difficult to independently verify and compare them. Some could contain grid connection costs, water surface rental/lease costs, and import taxes and duties on PV modules and other components. In some cases, costs may be affected by stringent local content rules, making them less comparable. Some projects benefit from grants for feasibility and engineering studies, thereby lowering development costs. Finally, from an engineering point of view, some projects are easier to implement than others (e.g., where the water depth is low and water levels vary little), considerably reducing project design, anchoring, and mooring costs.

To date, most of the projects operational outside China are small ones of around 5 megawatt-peak (MWp) or less, with the exception of a few large installations in Japan and the Republic of Korea. But the FPV market is burgeoning and many large-scale projects (ranging between 20 and 150 MWp) are currently under development or construction in various countries in the world. It will be interesting to watch the evolution of capital expenditure (CAPEX) in the market to see how economies of scale affect investment costs. Obviously, the costs of small systems can vary significantly by location.

On a per watt-peak basis, the CAPEX of FPV projects is still slightly higher than of ground-mounted PV, mainly due to the expenses of the floating structure (the number of floats required depends on the design), the inverter floating platform (where relevant), and the anchoring and mooring system. It is fair to expect that the costs of floats will drop over time. The FPV mar-

ket is still at a nascent stage, and cumulative installed capacity is only about 1.3 gigawatt-peak (GWp) (the total global installed PV capacity was about 500 GWp at the end of 2018). However, the extent to which costs will drop is difficult to predict, especially since HDPE floats remain dependent on crude oil prices. If nothing else, economies of scale should help to reduce costs as the scale of float production increases and experience from past production and deployment is applied. Nevertheless, the design of the floating structure and its anchoring and mooring system will always remain site sensitive, and costs will vary depending on the complexity of the engineering challenges involved. However, unlike ground-mounted PV, generally no heavy civil engineering work is required to set up an FPV installation. On this basis, a 2017 International Finance Corporation (IFC) report<sup>20</sup> estimates that for a “cost per watt-peak” installed, FPV should not deviate significantly from ground-mounted PV installations. This has been confirmed by recent FPV tenders.

Information on FPV investment costs, mainly retrieved from public press releases, are summarized in figure 5.1. Projects have been sorted by their month of commissioning. Total CAPEX for FPV systems in 2018 ranged between \$0.8 and \$1.2 per watt-peak, depending on the location, water body depth and variation, and system size. Large projects on deep-water reservoirs are likely to be the most complex, pushing up project development and capital costs. That said, based on the interviews with industry experts, the scale matters for projects up to about 30 MWp, after which economies of scale become less significant.

As can be seen in figure 5.1, system prices remain relatively high in Japan. China and India have achieved much lower FPV costs than the global average, a trend also observed for ground-mounted and rooftop solar systems. A 500 kilowatt-peak (kWp) FPV system in Kerala, India, is an exception: here only high-quality components were used without any attempt to realize cost-benefit efficiencies.

20. “Task 1: Commercial Readiness of FSPV—Global Market and Performance Analysis,” in Planair and PITCO (2017).

In March 2018, the India-based West Bengal Power Development Corporation Limited announced the results of an EPC tender for a 5 MWp FPV system to be developed in the district of Murshidabad, on a raw water pond of the Sagardighi Thermal Power Project. International Coil Limited, with the support of Ciel & Terre International, won the turnkey EPC bid with the lowest quote of Rs. 269.12 million (no grants provided) (Prateek 2018), which corresponds to about \$4.13 million or \$0.83/Wp (using the 2017 average annual exchange rate). The average price of the five bidders (i.e., International Coil Ltd, Adani Infra, Vikram Solar, Sterling and Wilson, and Giriraj Renewables) was substantially higher at \$1.14/Wp.

Future capital costs will depend on the costs of solar modules as well as the development of new floating technologies, beyond HDPE plastic floats that are the most common floating structures on the market today.

### 5.1.1 Capital expenditure

The main difference between the cost of investing in ground-mounted or FPV resides in the floating structure and the related anchoring and mooring system, which are highly site specific. There are too few data points available in the nascent market to provide an “average” cost figure with a high level of confidence. Another issue that affects costs is the use of direct current (DC) (in some cases submarine) electric cables with additional insulation and shielding properties to protect them from moisture degradation, thereby adding a premium to the CAPEX of FPV when compared to ground-mounted PV.

The following subsections outline reasonable assumptions regarding the average cost per component of a hypothetical 50 MWp FPV system on a freshwater, inland reservoir (with a maximum depth of 10 meters and minimal water level variation).

**FIGURE 5.1. FPV investment costs, 2014–18 (realized and auction results)**

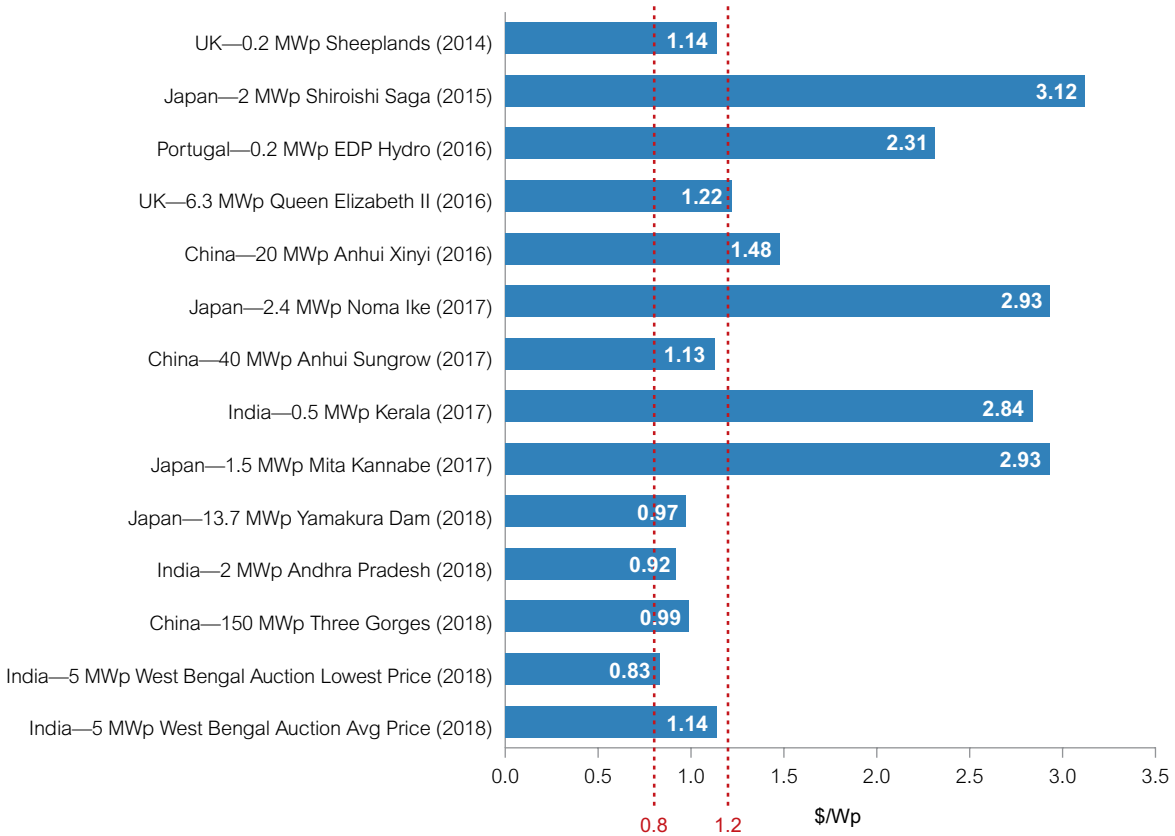

Source: Authors' compilation based on media releases.

Notes: Using 2017 U.S. dollar annual exchange rates, as released by the Organisation for Economic Co-operation and Development. FPV = floating photovoltaic; MW = megawatt; \$/Wp = U.S. dollars per watt-peak.

The cost component assumptions used in this chapter are based on the experience and investigations of the Solar Energy Research Institute of Singapore (SERIS), and guidance from equipment suppliers, EPC contractors, and developers. It is important to reiterate that these figures are estimates that will need to be adjusted once more data become available after the completion of more large-scale FPV systems across the world. Also, the cost of a specific FPV project will depend on its design and location.

#### **Solar PV module**

There are no particular standards for FPV modules. The most commonly used are framed glass-glass mono- or polycrystalline silicon modules with 60 cells or 72 cells.

This design is relatively resistant to moisture. Frameless modules have been used in some projects, especially for floats using membranes, as they allow for direct contact with the surface and eventually also reduce the risk of potential induced degradation (which rises when humidity rises). It is also too early to confirm that glass-glass modules perform better than glass-backsheet modules. PID-free or glass-glass modules could be advantageous where humidity is high, but generally come at a slight price premium.

In this analysis, a standard PV module price of **\$0.25/Wp** is used to calculate the levelized cost of electricity (LCOE). This is considered representative of the average price of polycrystalline silicon (poly-Si) mod-



ules (with efficiencies typically in the range of 17–19 percent)<sup>21</sup> and of mono-Si high-efficiency/passivated emitter rear cell (PERC) modules from Chinese manufacturers (with a typical efficiency greater than 20 percent)<sup>22</sup> in the third and fourth quarters of 2018. As reported by EnergyTrend and as a direct consequence of China’s “531” policy, the average prices of mono- and polycrystalline silicon modules fell by 19.8 percent and 25.5 percent, respectively, in the first three quarters of 2018 (Bellini 2018).

No import or safeguard duties were assumed in the estimates of PV module prices. Currently, most large-scale FPV plants are deployed using pontoon-type floats, with PV panels mounted at a fixed tilt angle.

A fixed array installation is simple to install in different types of reservoirs, and the space needed between PV panels is relatively small. Furthermore, its complexity and thus its cost is low, and the system does not occupy a large surface area. Since this type of installation does not require any moving parts, it is relatively resilient and needs little maintenance (ERM—ADB/ Da Nhim—Ham Thuan—Da Mi Hydro Power Joint Stock Company 2018).

### ***Inverter***

Unlike solar PV modules, inverter prices are negotiated at a regional level; hence, no exchange price data are available for estimating a global benchmark price. However, inverter prices have come under similar pressure as panel prices; it is likely that they will continue to fall, gradually, levelling off in the medium term.

Both string and central inverters have been used in FPV installations around the world. Generally, central inverters are used for large-scale FPV systems and string inverters for smaller systems. Inverters can either be installed on the surface of a water body (on a floating pontoon) or on land (typical for smaller systems). If inverters are mounted on floats, they should have an ingress protection rating of at least IP67 to withstand the high moisture.

21. EnergyTrend, 2018/11/07 update.  
22. PVinsights, 2018/11/04 update.

The estimated average price of central inverters for a solar PV system of about 50 MWp is about **\$0.06/Wp**; this is the price used in the LCOE calculations. This figure is in line with the inverter cost estimates for utility-scale PV systems cited in NREL (2017).

### ***Floating structure, anchoring and mooring system***

HDPE floats are the most common, cost-competitive structure used for FPV plants. The quality of the HDPE material, including additives for long-term durability, is important to consider. Potential investors and developers should ensure that floats are sourced from high-quality manufacturers with a strong track record. Floats should also be recyclable, nontoxic, resistant to ultraviolet radiation, salt corrosion, water, alkalis, and acids, and have a lifetime of over 20 years. Experience from the maritime industry has shown that a lifetime of 20–25 years (and even longer) is possible. As a safety measure, particularly when being installed on a drinking water reservoir, floats should be food grade and compliant with strict drinking water tests.

Because they are the most common, costs of high-quality HDPE floats were used to calculate the LCOE in this analysis. Anchoring and mooring costs are included in the total price of floats. Their costs vary according to site conditions, such as local wind load (more anchoring points are needed where winds tend to be strong) and maximum depth and water level variation (where the level fluctuates widely, more complex mooring is required). A system in calm and shallow waters, for example, could simply be anchored to a bank. The design of the floating structure and the anchoring and mooring system, and to a certain extent cabling costs, depends on the following input parameters:

- Bathymetry (including subsurface soil conditions)
- Water-level variation
- Wind and wave characteristics
- Type of banks (for launching)
- Water quality and level of salinity

Another important cost relates to logistics and transport; HDPE floats have a high volume-to-weight ratio. For larger systems, local manufacturing processes

using redeployable equipment may be worth considering.

Recent (2018) cost estimates of pure HDPE floating structures (including anchoring and mooring) range between \$0.14/Wp and \$0.22/Wp. An estimate of **\$0.15/Wp** is used in the LCOE calculations. This would be for a standard, large-scale FPV project of 50 MWp that does not require a complex anchoring and mooring system, and whose floats can be produced locally.

Even though straightforward HDPE float islands offer an ideal solution in many cases, structures with frames or various mooring and anchoring systems might be better suited to certain environments and climates. According to the Solar Energy Application Centre in the Netherlands and findings from its pilot test “Zon op Water,” HDPE floats may not offer the most durable solution under certain conditions (Hutchins 2018). A researcher at the Solar Energy Application Center (SEAC) in Eindhoven stated, “We are also testing steel systems, where you build up mounting structures from a steel pipe, and another which is based on a floating cement used in the marine industry—it is pretty solid and easy to walk on, and has a type of foam on the underside.”<sup>23</sup> Such alternatives to HDPE floats are typically more expensive, and their feasibility requires further research (and also depends on prevailing steel prices).

#### ***Balance-of-system components: Cabling, combiner box, switchboard, transformer, and others***

It was observed in some sections of the SERIS tested in Singapore that the insulation resistance of the systems dropped in certain instances. This in turn caused the inverters to temporarily shut down for safety reasons, that is, because a current leakage was suspected. This sequence of events might have been prompted by the high moisture content around the insulation of the cable. At this stage, no specific standards have been developed for floating PV cables, but in some cases enhanced cabling insulation might be

required, which would have a direct impact on costs. Electrical cable routing and the slack needed for the constant movements of the floating installation also affect the balance-of-system costs.

The rest of the equipment required, such as the combiner boxes, a switchboard, transformer, and a proper monitoring system are not different from those needed for ground-mounted PV projects.

An estimate of **\$0.13/Wp** for the balance-of-system components is used in the LCOE calculations.

#### ***Design, installation, civil works, testing, and commissioning costs***

Typically, HDPE float islands are easy to install and can be quickly mounted on the banks of a water body or on a platform. Certain civil works and site preparation elements may need to be constructed such as an inverter housing structure (floating or on land) or a dedicated launching platform (dependent upon accessibility to the water surface). However, heavy civil and foundational works are in most cases not required for FPV projects, as it is for ground-mounted PV projects.

With regards to the speed of FPV installation, leading float manufacturers report that a team of 50 trained installers can deploy between 500 kWp and 1 MWp per day, provided that a supply chain is in place.

Even though the costs outlined in this subsection can vary substantially across projects; an estimate of **\$0.14/Wp** is used in the LCOE calculations.

#### ***Grid interconnection costs***

Another factor relevant to costs is the availability of existing grid interconnection infrastructure. Grid connection, upgrades, or additional substations might be required where transmission and distribution infrastructure are not present or are inadequate. Where an FPV system is located close to a load center or hydro-power plant, the costs of grid interconnection will be

23. <https://www.pv-magazine.com/2018/11/03/staying-afloat-whatever-the-weather/>

much lower since the system can benefit from existing electrical infrastructure.

To simplify the LCOE calculations, it is assumed that there are no grid interconnection costs.

### Summary

The average total investment cost of an FPV system in 2018 varied between \$0.8/Wp and 1.2/Wp, depending on the system's size and location. The West Bengal EPC auction prices (unsubsidized) are from March 2018; other listed projects were completed in the first half of 2018, and would have included higher PV module prices. The CAPEX of large-scale but relatively uncomplicated FPV projects (around 50 MWp) was in the range of \$0.7–\$0.8/Wp in the third and fourth quarters of 2018, depending, of course, on the location and the type of modules involved.

The CAPEX of a hypothetical 50 MWp FPV installation is laid out in figure 5.2 and table 5.1, by component, and also compared with a ground-mounted system (both fixed tilt) at the same location. The module and inverter costs of both types of systems are assumed to be identical. The costs of the mounting structure (including, in the case of the FPV system, a floating structure as well as anchoring and mooring) and balance-of-system costs are significantly higher for FPV projects than for

ground-mounted PV. On a per-watt-peak basis, industry experience indicates that the CAPEX for FPV projects tends to be \$10 cents higher than for ground-mounted PV projects under similar conditions.

With increased competition and higher economies of scale, the future cost of float structures is expected to drop further. But, it is to be hoped that quality will not be compromised.

**TABLE 5.1. A comparison of capital investments: Floating vs. ground-mounted photovoltaic systems**

CAPEX component	FPV 50 MWp (\$/Wp)	Ground-mounted PV 50 MWp (\$/Wp)
Modules	0.25	0.25
Inverters	0.06	0.06
Mounting system (racking)*	0.15	0.10
BOS**	0.13	0.08
Design, construction, T&C	0.14	0.13
Total CAPEX	0.73	0.62

Source: Authors' compilation based on 2018 industry data.

Note: \*For FPV, the mounting system includes a floating structure, and anchoring and mooring system. \*\*Including monitoring system. BOS = balance of system; CAPEX = capital expenditure; MWp = megawatt-peak; PV = photovoltaic; T&C = testing and commissioning; \$/Wp = U.S. dollar per watt peak.

**FIGURE 5.2. Investment costs of floating vs. ground-mounted photovoltaic systems, by component**

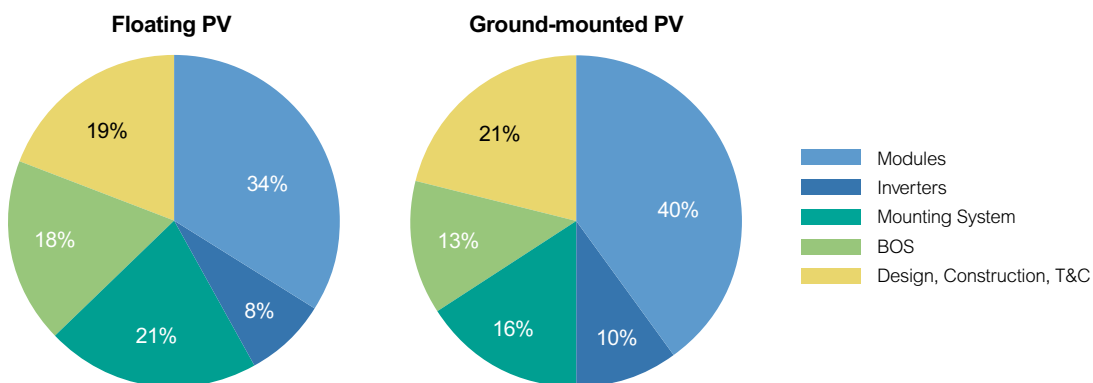

Source: Authors' compilation based on 2018 industry data.

Notes: Numbers are indicative only, for a hypothetical 50 megawatt-peak system. BOS = balance of system; MWp = megawatt-peak; PV = photovoltaic; T&C = testing and commissioning.

### 5.1.2 Operating expenditures

The main operating costs of an FPV system are identical to those of ground-mounted PV: the leasing or rental of the space where the system will be installed (but in the case of FPV it's a water body, not land), operation and maintenance (O&M), insurance, and inverter replacement costs. A lease or rental fee will not be considered in the LCOE calculations here, for FPV or ground-mounted PV, since this cost varies so widely across locations and projects. Nonetheless, it is likely that the cost of leasing a water body is cheaper than leasing land, since the water body is not in competition with agriculture or real estate development.

#### Operation and maintenance

Based on industry experience, O&M costs can vary a lot across jurisdictions and according to the investment strategy of the developer/owner. Even though the use of boats, or in some circumstances even divers, might increase O&M costs at certain times, industry representatives indicate that these costs are generally comparable to those of ground-mounted PV over the lifetime of a project. When placed on water bodies, solar panels will generally incur less soiling from dust, and the water needed to clean them is directly available. However, corrosive bird droppings have been reported in Singapore and the United Kingdom. Their effects should not be underestimated since they could negatively affect the energy yield if panels are not cleaned regularly (thus driving up maintenance costs), particularly in areas where avian life is abundant. Using remotely operated robotic systems to clean the panels,

and an underwater robot to inspect the mooring may also be viable options.

As with CAPEX, the O&M costs of an FPV system will vary depending on the site's conditions. Depending on the wind forces present on the site, annual inspection of the mooring cables and sporadic inspection of the anchoring system should be performed. The need for maintenance also strongly depends on the variation of water level that the plant undergoes. Likewise, replacement of parts of the equipment is more complicated and time intensive. Since operating on a more or less deep-water body, worker safety is another aspect that needs to be considered and potentially adds to the maintenance cost.<sup>24</sup>

One FPV developer, Ciel & Terre International, lists typical annual O&M efforts on its website as two man-days per MWp to check the floating structure, plus three man-days per MWp every three years to check the mooring and anchoring.

But O&M costs are difficult to estimate. For example, leading renewable energy institutions and developers of utility-scale ground-mounted PV projects use very different assumptions (see table 5.2).

Thus, O&M costs will vary significantly depending on the project's environment, the investor's strategy, and also the related labor costs. In the LCOE calculations used for this analysis, a general assumption of **\$0.011/Wp** is used for the first year. In the real world, this figure would vary significantly depending on where the proj-

**TABLE 5.2. Estimated operating and maintenance costs of ground-mounted photovoltaic systems (fixed tilt), various sources**

Utility-scale fixed tilt	O&M (\$/Wp/year)	Geographic focus
NREL (September 2017)	0.0154	United States
Lazard v12.0 (November 2018)*	0.009	United States
Fraunhofer ISE (March 2018)	2.5% of CAPEX	Germany

Source: Lazard 2018; NREL 2017; Fraunhofer ISE 2018.

Note: \*Same figure as reported in Lazard LCOE Analysis v11.0 dating from November 2017. CAPEX = capital expenditure; NREL = National Renewable Energy Laboratory; \$/Wp = U.S. dollar per watt-peak.

24. "Task 1: Commercial Readiness of FSPV—Global Market and Performance Analysis," in Planair and PITCO (2017: 30).

ect is located (Europe, the United States, India, or China, for example) and the general climate conditions. It is therefore important to include relevant sensitivities in this particular cost item. Industry experience with O&M costs over the lifetime of an FPV project is nascent, and the assumptions here may be found to be overly conservative.

### **Insurance**

Similarly to ground-mounted PV, different types of insurance coverage exist, including policies covering physical and/or nonphysical damage risks. Premiums vary widely depending upon the location of the project, system design and quality, and climatic conditions. According to a report from SolarBankability on general PV investments (2017: 26):

Insurance coverage for technical risks is available both during the project's construction and operational phase. The former phase can be covered by a general liability and a construction insurance. The latter phase can be covered by a general liability, a property damage, a business interruption, and optionally by a performance guarantee insurance. The coverage is offered for technical risks caused by external root causes such as storm, external surges, fire, theft, etc. Usually, the insurance includes a deductible which the PV system owner has to cover himself. The business interruption insurance covers revenues lost on power feed-in for the duration of a breakdown of up to 12 months. In recent years, insurers started to differentiate insurance premiums between new and used PV systems, with significantly higher premiums for aged PV systems. In case of an insurance claim, the insurer usually reserves the right to cancel the insurance.

For performance guarantee insurance—such as a system output guarantee protecting against a reduced system performance ratio (PR) or reduced solar irradiation—the cost will vary depending on the percentage of the revenues insured (e.g., 90 percent, 85 percent, or 80 percent of P50<sup>25</sup> output), the project's materials and design, among other variables. The insurance premium can be paid up front or in installments, subject to the project size, and will protect the project's rev-

---

25. <https://solargis.com/blog/best-practices/how-to-calculate-p90-or-other-pxx-pv-energy-yield-estimates/>

enues for a period of up to 10 or 12 years. This type of coverage is optional and will depend upon the risk appetite of the sponsors/owners of the system and/or the lenders. According to 2018 data, the estimated cost of insurance for both irradiance and entire PR risks for a 50 MWp FPV system are about 0.8–1.2 percent of insured revenues, on average (this would typically cover 85–90 percent of the P50 output). A one-off insurance cost premium of about \$1.1 million would be paid up front and cover irradiance and PR risks for 10 years (to match with the debt tenure). Using a 50 MWp FPV system cost of \$0.73/Wp, equivalent to a total system cost of \$36.5 million, this insurance premium would be equivalent to 3 percent of the total system cost or to 0.3 percent of the system cost on an annual basis (for 10 years). Yet these numbers are solely indicative, and additional research and comparison should be performed on a project basis.

According to Speer, Mendelsohn, and Cory (2010), the annual cost of insurance can range from 0.25 percent to 0.5 percent of total CAPEX (and it is highest in areas where extreme weather events are likely). Premiums will vary over time.

The insurance cost used for the LCOE calculations is 0.3 percent of the system price, paid annually and adjusted to the inflation rate. This assumption is similar to the one used for large-scale ground-mounted PV projects due to a lack of empirical data received from the industry. More data needs to be collected from the implementation and realization of FPV projects across the world to better understand what potential distinctive factors from ground-mounted PV projects could be. An FPV insurance premium could be applied in certain instances, especially when projects are built in environments that are more complex.

### **Inverter replacement**

Similar to ground-mounted PV plants, certain plant components will need to be replaced over an FPV system's operating lifetime even though most should be operational for at least 20 years. The highest risk comes from the inverters. Experience from the field shows that a "mean time between failures" of 1-16



years can be observed, and inverter manufacturers typically offer warranties over a 5-12 year period. Therefore, with an offtake contract tenure of 20 years, the replacement cost of inverters needs to be taken into account at least once during the operation of the PV assets. Apart from accounting for the replacement cost of inverters at the time of failure, the inverter supplier usually offers an option of buying a warranty extension for another five years at about 20 percent of the prevailing inverter cost. A detailed cost-benefit analysis needs to be carried out to compare the expected operating lifetime of the inverters against the cost of warranty extension.

For this present analysis, it is assumed that the warranty will be extended in five-year intervals. The warranty extension cost is assumed to increase with the age of the inverter portfolio. An inverter manufacturer might be less willing to extend a 10-year-old inverter portfolio (when some but probably not all inverters were replaced in the previous five-year period) than a 5-year-old one. For the base case, it is assumed that the warranty extension cost will be 20 percent of the prevailing inverter price in year 5, 45 percent in year 10, and 60 percent in year 15. The increase of the premium reflects the inverter supplier's reluctance to extend the warranty in line with the increasing age of the inverter fleet. Inverter prices are assumed to continue a slow declining trend, leveling out at about \$0.05/Wp in year 10. The nominal amount of all inverter warranty expenses over the project's 20 years of operation would be calculated on an annual basis (not discounted) at about \$200,000 (equivalent to \$0.004/Wp). Based on this methodology, the inverters are assumed to be replaced about 1.33 times in the 20-year period.

Some inverter manufacturers also offer the option of paying a one-off premium to extend the 5-year inverter warranty into a 20-year warranty, at a cost equivalent to about 60-70 percent of the initial inverter purchasing price. Based on an initial price of \$0.06/Wp, this would add a cost of \$0.039/Wp to the initial investment costs, which is quite significant. This option has therefore not been modelled.

### 5.1.3 Residual value/decommissioning

In this example, it is assumed that the residual value of the floats (recycled plastic), the module frames (aluminum), and the cables (copper) would be used to cover decommissioning costs. This assumption will need to be further verified with additional experience from the industry and as FPV projects reach the end of their operating lifetime.

## 5.2 Calculating the levelized cost of electricity

### 5.2.1 Financial assumptions

Financial assumptions vary substantially from one country to another, and largely depend on which risk mitigation mechanisms have been put into place to ensure the reliable operations of an FPV system over 20 years. Experience from sponsors, developers, and EPC and O&M contractors are paramount to build trust among investors. Given that the deployment of large-scale FPV systems remains limited to date, lenders and potential institutional investors might require a higher cost of capital to compensate for the lack of experience in this market segment. Three WACC scenarios are therefore considered. The same financial assumptions have been used to calculate the LCOE of hypothetical 50 MWp ground-mounted and FPV systems, as detailed in table 5.3.

**TABLE 5.3. Financial assumptions used to calculate the levelized cost of electricity for 50 MWp ground-mounted and FPV projects**

	Assumption
Debt equity ratio	80:20
WACC	Scenario A: 6% Scenario B: 8% Scenario C: 10%
Debt premium	4%
Maturity of loan	10 years
Inflation rate	2%
Economic system life	20 years

Source: Authors' compilation.

Note: LCOE = levelized cost of electricity; MWp = megawatt-peak; WACC = weighted average cost of capital.

**BOX 5.1**

**Methodology**

The LCOE is calculated by dividing the entire lifecycle cost of an FPV system by its cumulative solar electricity generation. It is presented in net present value terms, with each year’s cost discounted by the investor’s hurdle rate. For this particular generic analysis, some simplifications have been used:

- No interest during construction, as lenders often offer a grace period
- No residual value/decommissioning cost
- No taxes, as these vary significantly across jurisdictions

The LCOE (before tax) formula used in this analysis is shown below:

$$LCOE = \frac{EPCI + \sum_{n=1}^N \frac{OM^* + IC^*}{(1+DR)^n} + \frac{IEI^*_{n=5,10,15}}{(1+DR)^{n=5,10,15}} + \sum_{n=1}^N \frac{LP}{(1+DR)^n}}{\sum_{n=1}^N \frac{(IRD \times PR) \times (1 - SDR)^n}{(1+DR)^n}} \quad \text{*Inflation adjusted}$$

Where:

- |  |  |
|--|--|
| EPCI = Equity project cost investment            | IEI = Inverter warranty extension investment |
| IC = Insurance cost                              | LP = Loan payment                            |
| N = Number of years in the system’s service life | IRD = Irradiance                             |
| OM = Operation and maintenance                   | PR = Performance ratio                       |
| DR = Nominal discount rate                       | SDR = System degradation rate                |

The numerator sums up all the possible cost items over the system’s entire lifetime. The investment cost comprises the equity project cost investment (EPCI). The annual operating cost is split in two parts, namely the operating and maintenance cost (OM) and the insurance cost (IC). The inverter warranty extension investment (IEI) represents the warranty extension cost for the systems’ entire operating life. The year in which the warranty is extended depends on inverter suppliers. The model assumes a warranty extension at years 5, 10, and 15. In case a part of the up-front CAPEX is debt financed, the loan payments (LP) include annual

interests and amortizations. The denominator includes the system’s lifetime electricity generation. The specific yield is the energy yield of the system in the first year, which is calculated by the product of the available irradiance (IRD) and the performance ratio (PR). After the first year, the generation output is annually adjusted according to the system degradation rate (SDR). Both values are discounted by the nominal discount rate (DR) for net present value calculations, which is based on the weighted average cost of capital (WACC) concept. OM, IC, and IEI are adjusted with the inflation rate after the first year.

**5.2.2 Energy yield**

The key difference between FPV and ground-mounted PV projects is the modelling of the cooling effect due to water evaporation. It has been reported across the world that FPV systems have a higher energy yield than ground-mounted PV systems under similar con-

ditions. Therefore, the irradiation level and ambient temperatures where the project is located are key variables that will influence the energy yield and thus the LCOE of projects.

Preliminary results show that in hotter climates, the energy yield gain of an FPV plant over a ground-mount-

ed one is higher than in temperate climates, since the cooling effect of water makes a great difference to their relative efficiency. This means that in certain regions of the world, the energy yield gain could be around 10 percent (typically in warmer regions with a global horizontal irradiation higher than 1,600 kilowatt-hour per square meters per year [kWh/m<sup>2</sup>/year]) while in other regions it would be only about 5 percent (typically in colder regions or where irradiation is lower than 1,600 kWh/m<sup>2</sup>/year). However, more studies are needed to verify this assertion and to more accurately quantify the correlation between energy yield gains and various climates. Because the FPV market is nascent and lacks empirical data, the analysis here uses preliminary estimates of the energy yield gain of FPV projects in three climates. These estimates are based on assumptions, and require verification when data become available.

Three types of climates are considered in the LCOE calculations: temperate, tropical, and arid/desert. Cold and polar climates have been excluded from the analysis as building large-scale solar PV plants in these regions is less likely.

The representative “average” P50 global horizontal irradiance and performance ratio for ground-mounted PV figures has been estimated for each climate zone (table 5.4). The performance ratio of FPV systems under similar conditions is estimated to increase by 5 percent in the conservative scenario and 10 percent in the optimistic scenario. The bold underlined PR values are the “likely” cases per climate zone.

Table 5.5 shows the energy output of hypothetical 50 MWp ground-mounted and FPV plants in their first year, across the three climates.

### 5.2.3 System degradation rate

As of the end of 2018, there are no sufficient records yet for the degradation rates of FPV systems. Generally, crystalline silicon modules degrade at a rate of no greater than 0.8 percent to 1.0 percent per year, respectively. It is assumed here that the annual system degradation rate is 1 percent (Ye et al. 2014) in a tropical climate, 0.7 percent in an arid/desert climate (Copper, Jongjenkit, and Bruce 2016), and 0.5 percent in a temperate climate (Jordan and Kurtz 2013).

**TABLE 5.4. Representative average global horizontal irradiance and performance ratio, by climate zone**

	GHI (kWh/m <sup>2</sup> /year)	Ground-mounted PR (%)	Floating PR (%)	
			Conservative (+5%)	Optimistic (+10%)
Tropical	1,700	75.0	78.8	<b>82.5</b>
Arid/desert	2,300	75.0	78.8	<b>82.5</b>
Temperate	1,300	85.0	<b>89.3</b>	93.5

Source: SERIS estimations based on: Baker et al. 2015; and Reich et al. 2012.

Note: GHI = global horizontal irradiance; kWh/m<sup>2</sup>/year = kilowatt-hours per square meter per year; PR = performance ratio.

**TABLE 5.5. First year’s energy output, by climate**

	Ground-mounted PV (GWh)	Floating PV (GWh)	
		Conservative (+5%)	Optimistic (+10%)
Tropical	63.8	66.9	<b>70.1</b>
Arid/desert	86.3	90.6	<b>94.9</b>
Temperate	55.3	<b>58.0</b>	60.8

Source: SERIS calculations based on estimated data.

Note: GWh = gigawatt-hour; FPV = floating photovoltaic; PR = performance ratio.

### 5.2.4 LCOE calculation results

The following assumptions were made for both ground-mounted and FPV technologies:

- No lease cost, since this varies widely across projects and regions
- No contingency costs (typically at 3 percent of EPC costs [NREL 2017])
- Same inverter replacement methodology

- Same insurance cost
- Same O&M costs: even though this assumption can be argued; therefore a sensitivity analysis on this variable (+15 percent for FPV) will be provided in the next section
- Same system degradation rate
- Calculated on a pretax basis

Ideally, to fine-tune this analysis, system prices, O&M costs, insurance, and inverter warranty extension costs

**TABLE 5.6. Summary of assumptions used in calculations**

General assumptions	Ground-mounted	Floating
System size (MWp)	50	50
System price (\$/Wp)	0.62	0.73
O&M costs (\$/Wp/year)	0.011	0.011
Yearly insurance (in % of system price)	0.3%	0.3%
Inverter warranty extension	Year 5: 20% of prevalent price Year 10: 45% of prevalent price Year 15: 60% of prevalent price ~\$0.004/Wp	Year 5: 20% of prevalent price Year 10: 45% of prevalent price Year 15: 60% of prevalent price ~\$0.004/Wp
Debt equity ratio	80:20	80:20
WACC	6% / 8% / 10%	6% / 8% / 10%
Debt premium (%)	4%	4%
Maturity of loan (years)	10	10
Surface lease cost (\$/year)	—	—
Inflation (%)	2%	2%
Years of operation	20	20

Climate-related assumptions	GHI (kWh/m <sup>2</sup> /year)	System degradation rate (%)	Ground-mounted PR (%)	Floating PR (%)	
				Conservative (+5%)	Optimistic (+10%)
Tropical	1,700	1.0	75.0	78.8	<b>82.5</b>
Arid/desert	2,300	0.7	75.0	78.8	<b>82.5</b>
Temperate	1,300	0.5	85.0	<b>89.3</b>	93.5

Source: SERIS.

Note: GHI = global horizontal irradiance; kWh/m<sup>2</sup>/year = kilowatt-hour per square meter per year; MWp = megawatt-peak; O&M = operation and maintenance; PR = performance ratio; \$/Wp = U.S. dollar per watt-peak; WACC = weighted average cost of capital.

**TABLE 5.7. Results of (before tax) calculations**

LCOE (\$cents/kWh)			Ground-mounted PV 50 MWp	Floating PV 50 MWp	
				Conservative (+5% PR)	Optimistic (+10% PR)
Tropical	WACC	6%	6.25	6.77	<b>6.47</b>
		8%	6.85	7.45	<b>7.11</b> base case
		10%	7.59	8.28	<b>7.91</b>
Arid/desert	WACC	6%	4.52	4.90	<b>4.68</b>
		8%	4.96	5.39	<b>5.15</b>
		10%	5.51	6.01	<b>5.74</b>
Temperate	WACC	6%	6.95	<b>7.53</b>	7.19
		8%	7.64	<b>8.30</b>	7.93
		10%	8.49	<b>9.26</b>	8.85

Source: SERIS calculations.

Notes: kWh = kilowatt-hour; LCOE = levelized cost of electricity; MWp = megawatt-peak; PV = photovoltaic; WACC = weighted average cost of capital. The bold LCOE values are the “more likely” cases per type of climate.

should also be varying by location/climate. Without empirical data on these particular variables, the analysis considers their costs to be similar across the three climate zones.

In the conservative scenario (+5 percent PR), the LCOE of the FPV system is between 8 and 9 percent higher than the LCOE of the ground-mounted PV system, while in the optimistic scenario (+10 percent PR), the FPV LCOE is only 3-4 percent higher than the ground-mounted LCOE (table 5.7). This difference is likely to reduce, become zero, or even reverse as FPV volumes grow and anticipated cost reductions are realized (installed capacity today is still very small compared to ground-mounted PV systems around the world).

The LCOE calculation represents only a “break-even” analysis—that is, if the tariff were set at the LCOE, the net present value of the project would be zero. Equity investors would presumably require a higher tariff from the offtaker to make the project economically viable for them, assuming debt financing was accessible.

### 5.3 Sensitivity analysis

The following scenario was chosen as the base case to perform a sensitivity analysis:

Base case = 50 MWp FPV system in a tropical climate with a WACC of 8% and an optimistic PR (+10%)  
LCOE (\$cents/kWh) = 7.11

Reduced CAPEX (-15 percent) and a higher performance ratio (88 percent) will have the highest positive impact on LCOE, while higher CAPEX (+15 percent) and a reduction of 5 years of the operational lifetime will have the highest negative impact on the LCOE, as depicted in figure 5.3. A 2 percent change in the WACC, even though not reflected in the figure but calculated in table 5.7, will also have a significant impact on the LCOE, almost as important as a 15 percent change in CAPEX. This highlights the fact that concessional financing from multilateral and bilateral lenders could boost FPV adoption.



**FIGURE 5.3. Levelized cost of electricity sensitivities vs. base case**

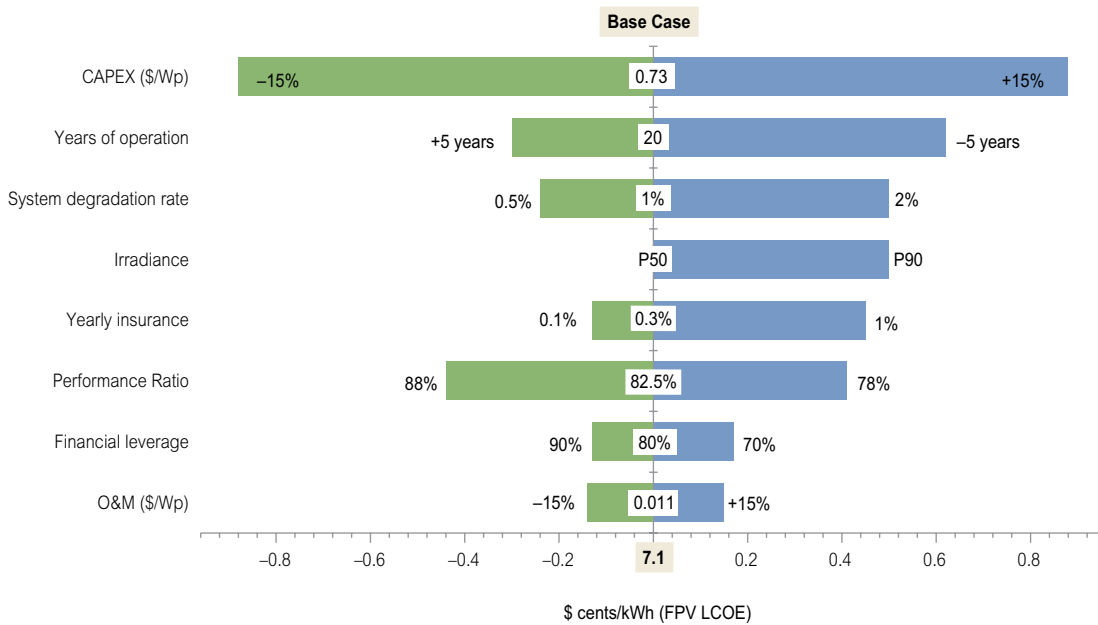

Source: SERIS calculations.

Note: CAPEX = capital expenditure; FPV = floating photovoltaic; LCOE = levelized cost of electricity; O&M = operation and maintenance; \$/Wp = U.S. dollar per watt-peak; \$ cents/kWh = U.S. dollar cents per kilowatt-hour.

## 5.4 Risk assessment

From a financing perspective, risks associated with new technologies like FPV are critical for the premium on interest rates compared to more established forms of PV deployment like ground-mounted systems. Five main risk categories are outlined in table 5.8.

## 5.5 Conclusion

There is no significant difference in the LCOE of ground-mounted, fixed-tilt systems and FPV installations. The higher initial capital costs of FPV systems are mostly balanced out by their higher energy output. Meanwhile, other considerations might favor FPV, such as the opportunity costs of using agricultural land. FPV costs are approaching those of ground-mounted systems and may converge in time, eventually leading to an equal or lower LCOE.

FPV deployment opportunities will be mainly driven by (i) jurisdictions where permitting favors them and where (ii) access to land and the scarcity/price thereof are major issues.

Compared to rooftop and ground-mounted PV installations, MW-scale FPV is brand new. This technology is at the earlier stages of its learning curve, and greater cost reductions are to be expected. This is not only true for the cost of the floating system itself, but also for engineering and project development costs. As will be shown in the following chapter, only a few EPCs have realized a sizeable number of FPV plants.

Finally, it is important to differentiate between risks and unknowns. Increased transparency and knowledge sharing with regards to the capital costs, environmental impact, and performance of FPV systems will help build trust among international investors and lenders, which will in turn help reduce financing capital costs.

**TABLE 5.8. Overall FPV risk assessment**

Risk category	Comment
Technology/capital expenditure (CAPEX) risk	<ul style="list-style-type: none"> <li>• Even though deployment of floating photovoltaic (FPV) systems remains limited to date, the technology risk on inland freshwater reservoirs is considered low given the fact that developers apply experiences from (i) the established forms of PV deployment, especially ground-mounted PV systems; and (ii) the offshore and maritime industry where floating structures made of high-density polyethylene (HDPE) and mooring and anchoring has been applied for decades. Nevertheless, quality matters, and especially floats (which have the shortest track record) need to undergo thorough stress testing and certifications of their long-term durability and reliability.</li> <li>• Mooring complexity, corrosion and aging, equipment fatigue, and the impact of waves and wind must be carefully analyzed to find the appropriate FPV system design. All of these elements will influence a project's structural and mooring costs.</li> <li>• "The floating dynamics of the FPV system may lead to fatigue-based micro-cracking in the panels over time. This will lead to reductions in the performance of the panels but the magnitude of this deterioration is not yet fully understood" (Leybourne 2017).</li> </ul>
Operation and maintenance (O&M) risk	<ul style="list-style-type: none"> <li>• In principle, the O&amp;M costs of FPV systems should not be higher than for ground-mounted PV, although accessibility may play a role, as in most cases boats need to be used and the replacement of components may be more complex.</li> <li>• O&amp;M requirements depend on the context. For example, severe soiling due to bird droppings will either increase O&amp;M costs or reduce energy yield if not dealt with properly.</li> </ul>
Financial risk	<ul style="list-style-type: none"> <li>• FPV is still at a nascent stage, hence the long-term data needed for statistical analysis and to assess the performance of loans do not exist. Most projects are still being financed on balance sheets.</li> <li>• Technical due diligence takes longer where nonrecourse (or limited recourse) project financing is involved due to FPV systems' lack of a track record. This can lengthen the process of reaching financial close. However, this risk is expected to reduce in time as more and more FPV projects are built around the world and their track record information becomes available to developers and financial institutions.</li> <li>• From an economic perspective, FPV projects will generally have a high share of domestic content, thereby having a positive impact on the local economy, as it is much more economical to manufacture HDPE floats locally. This in turn will have a positive impact on job creation, local-currency funding, and the development of a local commercial financial sector (reducing foreign exchange risks, unlike when most equipment is imported).</li> <li>• Interestingly, Sungrow reported the following on the bankability of FPV systems: "The banks are willing to provide us financial support because even though the ROI of these floating plants can be a little bit lower than the other ground-mounted PV plants, this kind of plant does not have a real estate problem" (PV Tech 2017).</li> <li>• It is expected that investors and financing organizations would collaborate with public or semi-public utilities that own a series of water bodies (e.g., water, rural/agricultural authorities) to adopt a portfolio approach with a series of projects in different geographic locations to diversify risks. In rural areas, it is important to involve local communities, especially if they are depending on the reservoir for other activities such as fishing.</li> </ul>
Regulatory risk	<ul style="list-style-type: none"> <li>• The ownership of the water body and/or water surface, as well as the contractual setup of FPV projects, is an important point to consider. This will vary by jurisdiction. In view of the lack of specific regulatory frameworks, diligent legal advice will be required to ensure that the right business model and project structure are chosen.</li> <li>• Enforcement of typical lenders' securities must also be analyzed as challenges may arise when the owner of the asset (FPV system) is not the same as the owner of the reservoir (surface).</li> <li>• "There are projects in which the opportunity for mitigating risks is not undertaken due to lack of clarity as to who bears the overall responsibility" (IEA 2017).</li> </ul>

**TABLE 5.8** *continued*

Risk category	Comment
Environmental risk	<ul style="list-style-type: none"> <li>• There is still a lack of empirical data on the long-term environmental impact of FPV installations on reservoirs. Developers tend to cover only small fractions of reservoirs and regularly monitor whether there are any adverse impacts on the water quality and flora/fauna. Installed projects to date (with a 2–3 year track record) have shown that they are not creating any negative environmental impacts.</li> <li>• This topic is of great importance to the FPV community and therefore will be addressed in detail in the next next publication of <i>Where Sun Meets Water</i><sup>1</sup> series, to follow shortly after this publication.</li> </ul>

Source: Authors' compilation.

Note: ROI = return on investment.

1. World Bank Group, ESMAP and SERIS. 2019. "Where Sun Meets Water: Floating Solar Handbook for Practitioners." Forthcoming. Washington DC: World Bank.

## References

- Baker, R. S., M. Bieri, W. K. Cher, K. Zhang, R. Rütger, T. Reindl, and A.M. Nobre. 2015. "National Solar Repository—5-Year Country-Wide Assessment of PV Systems' Performance in Singapore." 31st European Photovoltaic Solar Energy Conference and Exhibition, Hamburg, Germany.
- Bellini, E. 2018. "Module Prices Have Decreased by up to 25% so Far This Year, TrendForce Says." PV Magazine, October 9. <https://www.pv-magazine.com/2018/10/09/module-prices-have-decreased-by-up-to-25-so-far-this-year-trendforce-says/>.
- Copper, J., K. Jongjenkit, and A. Bruce. 2016. "Calculation of PV System Degradation Rates in a Hot Dry Climate." Conference paper at Asia Pacific Solar Research Conference, Canberra, Australia, December 2016.
- Energy Trend. <https://www.energytrend.com/pricequotes.html>. 2018/11/07 update.
- Fraunhofer ISE. 2018. "Levelized cost of electricity—Renewable energy technologies", Freiburg, Germany, March 2018. Authors: Christoph Kost, Shivenes Shammugam, Verena Jülch, Huyen-Tran Nguyen, Thomas Schlegl.
- Hutchins, M. 2018. "The Weekend Read: Staying Afloat, Whatever the Weather." PV Magazine, November 3. <https://www.pv-magazine.com/2018/11/03/staying-afloat-whatever-the-weather/>.
- IEA (International Energy Agency). 2017. *Technical Assumptions Used in PV Financial Model: Review of Current Practices and Recommendations*. Report IEA PVPS T13 08-2017. Switzerland: International Energy Agency Photovoltaic Power Systems Programme.
- Jordan, D. C., and S. R. Kurtz. 2013. "Photovoltaic Degradation Rates—An Analytical Review." *Progress in Photovoltaics: Research and Applications* 21 (1): 12–29.
- Kenning, T. 2018. "Akvo Energy Starts Construction on 17MW Floating Solar Plant in France." PV Tech, September 25. <https://www.pv-tech.org/news/akvo-energy-starts-construction-on-17mw-floating-solar-plant-in-france>.
- Korea Energy Agency. N.d. "Renewable Portfolio Standards(RPS)." [http://www.energy.or.kr/renew\\_eng/new/standards.aspx](http://www.energy.or.kr/renew_eng/new/standards.aspx).
- Lazard. 2018. "Lazard's levelized cost of energy analysis—version 12.0", November 2018.
- Leybourne, M. 2017. "Floatovoltaics—Thinking Beyond the Cost of Floating Solar PV." LinkedIn, July 4. <https://www.linkedin.com/pulse/floatovoltaics-thinking-beyond-cost-floating-solar-pv-mark-leybourne/>.
- Lightsourcebp. 2016. "Reservoir Floating Solar." Lightsourcebp, May 2. <https://www.lightsourcebp.com/uk/stories/qe2/>.
- Mass.gov. N.d. "Solar Massachusetts Renewable Target (SMART) Program: General Information." <https://www.mass.gov/info-details/solar-massachusetts-renewable-target-smart-program#general-information->.
- Ministry of Economic Affairs. 2018. "2018 Renewable Energy FIT Rates Are Announced." Bureau of Energy, Ministry of Economic Affairs, January 25. [https://www.moea.gov.tw/MNS/english/news/News.aspx?kind=6&menu\\_id=176&news\\_id=76457](https://www.moea.gov.tw/MNS/english/news/News.aspx?kind=6&menu_id=176&news_id=76457).

- Netherlands Enterprise Agency. N.d. "Stimulation of Sustainable Energy Production (SDE+)." <https://english.rvo.nl/subsidies-programmes/sde>.
- NREL. 2017. "U.S. Solar Photovoltaic System Cost Benchmark: Q1 2017", September 2017. Authors: Ran Fu, David Feldman, Robert Margolis, Mike Woodhouse, and Kristen Ardani.
- Planair and PITCO. 2017. *Assessment of Floating Solar PV Potential for Pakistan; Task 1: Commercial Readiness of FSPV—Global Market and Performance Analysis*. Unpublished report prepared for International Finance Corporation, Washington, DC.
- Prateek, S. 2018. "Breaking: West Bengal Auctions 5 MW of Floating Solar PV." Mercom India, March 16. <https://mercomindia.com/west-bengal-auctions-5-mw-floating-solar-pv/>.
- PV Tech. 2017. "World's Largest Floating Solar Project: Making Use of the Unusable." PV Tech Power Volume 12, September 2017. <https://www.pv-tech.org/technical-papers/worlds-largest-floating-solar-project-making-use-of-the-unusable>.
- PVinsights. <http://pvinsights.com/index.php>. 2018/11/04 update.
- Reich, N. H., B. Mueller, A. Armbruster, W. G. J. H. M. van Sark, K. Kiefer, and C. Reise. 2012. "Performance Ratio Revisited: Is PR > 90% Realistic?" *Progress in Photovoltaics: Research and Applications* 20 (6): 717–26.
- SolarBankability. 2017. "Technical Bankability Guidelines—Recommendations to Enhance Technical Quality of Existing and New PV Investments." SolarBankability, February 15.
- Speer, B., M. Mendelsohn, and K. Cory. 2010. *Insuring Solar Photovoltaics: Challenges and Possible Solutions*. Technical Report NREL/TP-6A2-46932 Revised February 2010. Golden, Colorado: National Renewable Energy Laboratory.
- Ye, J. Y., T. Reindl, A. G. Aberle, and T. M. Walsh. 2014. "Performance Degradation of Various PV Module Technologies in Tropical Singapore." *IEEE Journal of Photovoltaics* 4 (5): 1288–94.
- World Bank Group, ESMAP and SERIS. 2019. "Where Sun Meets Water: Floating Solar Handbook for Practitioners." Forthcoming. Washington DC: World Bank.





UNITED KINGDOM

© Lightsource BP Floating Solar Array, London.



# 6 SUPPLIERS OF FLOATING PV SYSTEMS

## 6.1. General overview

The ecosystem of floating photovoltaic (FPV) power is similar to that of other PV applications, with the addition of suppliers of float systems. The main industry players are investors, sponsors, developers, contractors (for services including engineering, construction, operation, and maintenance), and suppliers (of PV modules, float systems, and other equipment and components). Many of these players are active in the ground-mounted and rooftop PV sector, and in other renewable energy systems.

A growing number of developers is expanding their portfolios to include FPV by integrating floating platform technologies. They often start by partnering with float suppliers. The new and unique element applicable to FPV is thus the design and supply of the floating platform as a key structural component, which often also includes the design and supply of the anchoring and mooring solution.

Among the float suppliers entering the market are inverter manufacturers, developers of large solar PV projects, suppliers of mounting structures, plastic manufacturers, and firms active in related engineering fields, such as offshore and marine industries. Some suppliers are start-ups; others are subsidiaries of players established in their own industry.

Most suppliers of FPV systems have their own proprietary design of floats and floating systems. Some manufacture their own floats, whereas others procure them from third parties. In addition, an increasing number of FPV system suppliers also offer engineering, procurement, and construction (EPC) and operations and maintenance (O&M) services, with a few being able to offer even full turnkey solutions (figure 6.1).

Float suppliers may cooperate with EPC contractors or developers to deliver complete FPV system solutions. For example, Ciel & Terre International collaborates with Innova Capital Partners in Colombia,<sup>26</sup> Akuo

**FIGURE 6.1. FPV ecosystem (simplified)**

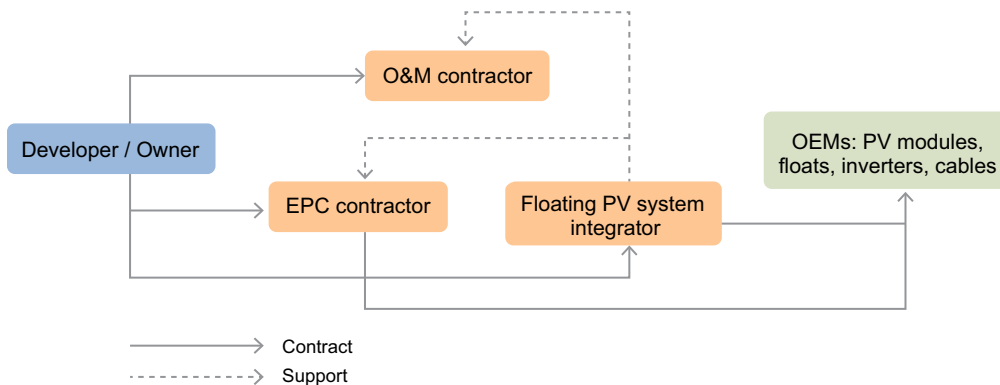

Source: Authors.

Note: O&M = operations and maintenance; EPC = engineering, procurement, and construction; OEM = original equipment manufacturer; PV = photovoltaic.

Energy in France, and D3Energy in the United States.<sup>27</sup> Some suppliers have even started certifying local EPC contractors. As a result, more and more EPC contractors with experience in ground-mounted or rooftop PV technologies are being trained to install FPV plants. With regard to the anchoring and mooring system, they generally borrow expertise from the marine industry, or even develop in-house expertise through their own research and development. For example, Sweden's Seaflex provides anchoring and mooring solutions for FPV in the Republic of Korea, India, and the United States, in partnership with FPV system suppliers. As a result of such collaboration, many float suppliers can provide design services, or at least advice, related to anchoring and mooring.

Some FPV system suppliers are also exploring near-shore or offshore floating applications, where different technologies and more robust designs are required. Section 6.3 offers a detailed look at several of these suppliers.

Apart from float suppliers, manufacturers of other equipment are exploring the development of products and solutions specifically for FPV applications. These include polymer resins, PV modules, inverters, DC cables, and other mechanical support components. However, this trend is still in its infancy and will not be covered in this chapter.

Table 6.1 presents a nonexhaustive list of FPV system suppliers as of end 2018. The first part lists major FPV system suppliers—i.e., those with a cumulative installed capacity in excess of 5 megawatt-peak (MWp); the second lists other FPV system suppliers. In both parts, the companies appear in alphabetical order. Many companies are entering the FPV market, so the table below is not exhaustive.

Some of the suppliers mentioned in table 6.1 are collaborating on FPV projects, such as LSIS and Scotra in Korea, where LSIS generally performs EPC and Scotra

26. <https://www.pv-tech.org/news/ciel-terre-and-innova-capital-to-develop-floating-solar-in-colombia>

27. <http://www.d3energy.com/about-us.html>

supplies the FPV system. These collaborations mean that certain projects appearing in the table may have been double-counted.

As of early 2019, the FPV market is currently dominated by two main system suppliers: Sungrow Floating and Ciel & Terre International. Both might be more accurately described as system integrators.

## 6.2. Providers of floating technology solutions for inland freshwater applications

This section describes in alphabetical order suppliers of FPV technology for inland freshwater applications that could claim an FPV installed capacity of at least 5 MWp in December 2018. The section 6.3 describes two suppliers of systems for offshore or near-shore applications of FPV. Some suppliers develop FPV systems for both inland and offshore applications.

### 6.2.1. Ciel & Terre International

Ciel & Terre International (C&T) has been developing FPV plants for commercial, industrial and government applications since 2011 (figure 6.2). By the end of 2018, the company had installed in excess of 300 MWp of FPV systems with more than 130 installations in 30 countries, including in Europe, the United States, India, Australia as well as in several Asian countries. More than 80 projects are in Japan, but the two largest—with capacities of 70 MWp and 32 MWp—are in China. The company's project portfolio shows experience in managing all aspects of a project's development by supplying design, financing, EPC, and O&M services.

C&T's brand Hydrelío, a modular system consisting of two types of HDPE floats, is a well-recognized brand in the industry. Three different models are currently available:

- The Classic (12° tilt)
- The Equatorial (5° tilt designed for lower-latitude countries)
- The aiR (adaptable angle up to 15°).

**TABLE 6.1. Nonexhaustive list of inland freshwater and offshore FPV system suppliers as of December 2018**

Company name	Country of origin	Services offered			Location of completed FPV projects	FPV technology	Total FPV capacity installed (MWp)	Total FPV capacity under development/ construction (MWp)	Website
		(Co-) Owner	Turn-key EPC	O&M					
<b>MAJOR FPV SYSTEM SUPPLIERS (INSTALLED CAPACITY ≥ 5 MWp)</b>									
Ciel & Terre International	France	●	◐	●	Worldwide	Specialized pure HDPE floats	319	330	https://www.ciel-et-terre.net/
Jintech New Energy	China	●	●	○	China	Specialized pure HDPE floats	150	80	http://www.jinnewenergy.com
Kyoraku Co.	Japan	○	◐	○	Japan, Taiwan, China, Thailand	Specialized pure HDPE floats	51	N/A	http://www.krk.co.jp/
LG CNS	Korea, Rep.	●	●	●	Korea, Rep.	Floating island + racks	6	80	http://lgcns.co.kr/
LS Industrial Systems Co.	Korea, Rep.	N/A	●	●	Korea, Rep., Japan	Floating island + racks	30	250	http://www.lsis.com/ko/
NorthMan Energy Technology	China	●	●	○	China	Specialized pure HDPE floats	230	N/A	https://netsolar.solarbe.com/
SCG Chemicals	Thailand	●	●	●	Thailand, Singapore	Specialized pure HDPE floats	5	N/A	https://www.scgchemicals.com/en
Scotra Co.	Korea, Rep.	N/A	●	●	Korea, Rep., Japan, Taiwan, China, Philippines	Floating island + racks	40.3	19.3**	http://www.scotra.co.kr/en/
Sumitomo Mitsui Construction Co.	Japan	●	●	●	Japan, Singapore, Thailand, Taiwan, China	Specialized pure HDPE floats	9.7	100	https://pv-float.com/english/
Sungrow	China	●	●	●	China, Germany, Israel, Japan, Philippines, Singapore, Thailand, Taiwan, China	Specialized pure HDPE floats	500	600	https://en.sungrowpower.com/product_category?id=22
Xiamen Mibet New Energy Co.	China	●	◐	●	Brazil, China, Germany, Israel, Japan, Southeast Asia, Spain, Taiwan, China,	Specialized pure HDPE floats	30	120	https://www.mibt-energy.com/

○ = No    ◐ = Limited support    ● = Yes    N/A = Not available

TABLE 6.1. continued

Company name	Country of origin	Services offered			Location of completed FPV projects	FPV technology	Total FPV capacity installed (MWp)	Total FPV capacity under development/construction (MWp)	Website
		(Co-) Owner	Turn-key EPC	O&M					
OTHER FPV SYSTEM SUPPLIERS (INSTALLED CAPACITY < 5 MWp)									
Floating Solar	Netherlands	N/A	●	●	Floating system design and procurement, tracking	N/A	N/A	https://floating-solar.nl/en	
ISIGENERE	Spain	○	●	●	Floating system design and procurement	Spain, Chile	1.9	https://isifloating.com.wordpress.com/	
Koiné Multimedia (Upsolar Floating)	Italy	○	●	○	Floating system design and procurement, tracking, concentration	Singapore, Italy, Korea, Rep.	0.4	http://www.koinemultimedia.eu/wp/	
NRG Energia	Italy	○	●	●	Floating system design and procurement	Italy, Iran, France, India, Canaries Island	1	http://www.nrg-energia.it/index-en.html	
Oceans of Energy	Netherlands	○	○	○	Floating system design and procurement, mooring systems	Netherlands	N/A	https://oceansofenergy.blue/	
Ocean Sun	Norway	○	●	○	Floating system design and procurement	Norway, Singapore	0.1	http://oceansun.no/	
ProFloating	Netherlands	○	●	○	Floating system design and procurement	N/A	N/A	https://profloating.eu/en/	
4C Solar	USA	N/A	N/A	N/A	Floating system design and procurement, tracking	Singapore, Chile, Maldives	N/A	https://www.4csolar.com/	
SolarisFloat	Portugal	N/A	N/A	N/A	Floating system design and procurement, tracking	N/A	20	https://www.solarisfloat.com/	

○ = No    ● = Limited support    ● = Yes    N/A = Not available

TABLE 6.1. continued

Company name	Country of origin	Services offered			Location of completed FPV projects	FPV technology	Total FPV capacity installed (MWp)	Total FPV capacity under development/ construction (MWp)	Website	
		(Co-) Owner	Turn-key EPC	O&M						Others
OTHER FPV SYSTEM SUPPLIERS (INSTALLED CAPACITY < 5 MWp)										
Solaris Synergy	Israel	○	●	○	Floating system design and procurement, tracking	Israel, Singapore, USA	Special island design with HDPE floats + frames	1	50	http://www.solaris-synergy.com/
Sunengy	Australia	○	○	○	Floating system design and procurement	India	Plastic concentrators with tracking, mounted on rafts (Liquid Solar Array) ***	N/A	N/A	http://sunengy.com/
Sunfloat	Netherlands	N/A	N/A	N/A	Floating system design and procurement, tracking (bifacial)	Netherlands	Floating island (with pipes) + aluminum frames	N/A	N/A	http://www.sunfloat.com/
Sun Rise E&T Corporation	Taiwan, China	○	○	○	Floating system design and procurement	Japan	Floating island (with pipes) + frames	N/A	N/A	http://www.srise.com.tw/v2/
Swimsol	Austria	●	●	●	Floating system design and procurement, floating substructure supplier	Maldives	Offshore modular floating platforms ***	0.2	0.4	https://swimsol.com/
Takiron Engineering	Japan	N/A	N/A	N/A	Floating system design and procurement	Japan	Floating island + racks	N/A	N/A	https://www.takiron.co.jp/english/

○ = No ● = Limited support ● = Yes N/A = Not available

Source: Authors' compilation based on information received from suppliers and/or their websites.

Notes: HPDE = high-density polyethylene. \*O&M for own projects only. \*\* Under construction, excluding bidding projects. \*\*\* R&D or early stage of commercialization.



**FIGURE 6.2. Examples of C&T FPV projects in Japan (left) and Brazil (right)**



Source: © Ciel & Terre International.



Source: © Ciel & Terre International.

The C&T system has been designed to be assembled like Lego blocks with screws and nuts made of polypropylene and fiberglass. The modular approach allows for installations from the kilowatt-peak (kWp) to the gigawatt-peak range. Hydrelío also offers ways to enhance the final design by adjusting the buoyancy, energy yield, Wp/m<sup>2</sup>, ease of access (for O&M), and footprint of the system layout.

C&T claims that its technology is tested to ensure endurance against severe tension loads over the lifetime of the plant. Being a modular technology, it allows for many different configurations and layouts, depending on the degree of buoyancy and stability required. To offer a bankable and long-lasting solution, C&T's FPV projects undergo testing for reliability, quality, and safety related to compliance with drinking water standards; floatability; and resistance to wind, waves, current, ultraviolet rays, and temperature, among others.

A key requirement for floats is not to affect water quality, especially when deployed in drinking water reservoirs. Hydrelío floats have been certified as "drinking water compliant" pursuant to tests performed by the English Independent Water Quality Control Center, attesting that the installation is safe on water intended for human consumption. C&T is also focusing on man-made reservoirs in which wildlife is limited or even entirely absent, with an eye to minimizing any poten-

tial adverse effects on the environment. This includes irrigation ponds, mining lakes, water retention ponds, waste water treatment ponds, industrial reservoirs, and hydroelectric dams.

The system is designed to be safe to install, as no heavy tools or machinery are required. Furthermore, during project development and construction, C&T offers system integrators assembly instructions and risk assessments such as development support, engineering expertise, EPC support, O&M services and financing solutions.

### 6.2.2. Kyoraku

Kyoraku Co., Ltd. was established in 1917 as a real estate development company initially. The company started manufacturing and selling plastics in 1947 to become one of the leading suppliers of plastics in Japan today. The company provides a wide range of plastic products used in various industries, including the food and beverage industry.

Based on their long-standing experience as a blow molder, Kyoraku has developed a floating structure specifically for floating solar systems, called the "Minamo Solar System". As of January 2019, the company has provided float structures for 33 different FPV projects totaling 51 MW. Most of the FPV systems are located in Japan (figure 6.3).

**FIGURE 6.3: Examples of Kyoraku's FPV systems in Japan**



Source: © Kyoraku.



Source: © Kyoraku.

Leveraging on their 60 years of experience in producing plastic containers for the high-standard food and medical industries, the company only uses food-grade material resin to develop their floats. They also have developed specific expertise in developing outdoor marine buoys.

The structure of their floats is relatively flat with few connections points. Their float system can resist 65 m/s wind speed and have undergone real scale wind tunnel testing.

### 6.2.3. LG CNS

Founded in 1987 in Korea, LG CNS is the first information and communications technology company in the country to make its way into the smart energy industry. The company applied its ICT capabilities to clean energy sources such as solar, wind, energy storage systems, and hydrogen to create integrated energy management solutions.

Within their solar segment, LG CNS is a developer and a turnkey provider of EPC plus financing. It is one of the few EPC companies and FPV solution providers to possess both technical and financial capability, having completed 6 MWp of large-scale floating projects (figure 6.4). LG CNS provides detailed and varied designs attuned to wind speed, water surface fluctuation rates, water depth and conditions, and moor-

ing types. The company handles the logistics of all components—including panels, structures, floating objects, and wiring.

Floating structures of LG CNS include multiple design configurations depending on the application and environment (e.g. wind load and water surface motion). They can include a frame (array), pure HDPE float matrix, as well as mats or membranes. Most of their larger FPV projects (more than 1 MWp) use a frame system whilst smaller projects (less than 1 MWp) typically use HDPE float matrix. According to the company, projects have witnessed increased energy yield ranging between 7 to 13 percent, and have been able to cope with humidity, rust and saline environments.

Ease of deployment with lightweight materials is a key feature of LG CNS systems. Design and systems have been tested to ensure structural safety including fatigue test under two million cycles of dynamic load, wind tunnel test, and other tests of load resistance and performance. Furthermore, environmental impact assessments have been conducted by various agencies to study the effects on water quality, sediment, aquatic life, and birds. These tests involve electromagnetism, temperature, humidity, light reflection, noise and odor tests, among others.

**FIGURE 6.4.** Sangju FPV systems built by LG CNS in Korea



Source: © LG CNS.



Source: © LG CNS.

**FIGURE 6.5.** LSIS FPV installations in Korea



Source: © LSIS.



Source: © LSIS.

#### **6.2.4. LS Industrial Systems (LSIS)**

In 2011, Korea's LSIS Co., Ltd. built the country's first FPV power plant at Hapcheon Dam, following research and development carried out in collaboration with K-Water. LSIS has experience with various aquatic environments, including dams, reservoirs, and run-off ponds (figure 6.5). LSIS and K-Water are currently researching FPV systems in marine environments.

LSIS's floating structure design is based on rigorous studies of stability under conditions of wind velocity (35 m/s), dead load, snow load, wave and flow velocity, and others, based on the Korean Building Code and the Harbor and Fishery Design Code. For use in aquatic environments, LSIS has developed an exclusive eco-friendly PV module that are completely lead-free; it is the first company authorized by the Korean government to use its PV modules as water supply equipment.

### 6.2.5. Scotra

Scotra is a leading supplier of FPV systems in Korea. It has constructed over 40 MWp of FPV systems there, including the country's largest, 18.7MWp at Gunsan Retarding Basin (figure 6.6). It also exports its FPV solutions to Japan, the Philippines, and Taiwan, China, among others. Scotra is the lead institution on a Korean government research project on FPV systems in marine environments. In that role, the company is focusing on structural stability and strength to withstand typhoons, and on eco-friendliness by minimizing the surface area of FPV installations.

The company claims to have built more than 1,200 floating structures since its establishment in 2004. Most have been for recreational purposes, such as marinas, water parks, buildings, bridges, stages, and mooring facilities. Scotra's FPV platform business began in 2011 with a partnership with K-Water, a Korean public corporation in charge of managing water resources, including dams. Because the difference in level between high and low water in some dams is more than 35 meters, Scotra tested a variety of mooring methods before arriving at an optimum system, the 360 degree multi-point catenary mooring method with patented elastic devices. Scotra is now applying to reservoirs the knowledge and expertise it gained in its dam projects.

Scotra has made substantial efforts to make its platforms eco-friendly. All three dams on which Scotra has built FPV platforms provide drinking water to the surrounding population. Minimal contact with the water surface is a feature of Scotra's eco-friendly design (only 10.6 percent of total FPV area), allowing substantially more sunlight to reach the water. To minimize effects on underwater ecosystems, including benthic organisms, the Scotra system does not block the natural flow of water. Ample free passages through the structure reduce O&M costs considerably. The minimal use of floaters, combined with solar panels' maximum exposure to open air, leads to more-efficient generation of electricity owing to the cooling effects of passing water and air. The company generally provides a three-year warranty on the float system, although this is negotiable.

Salt water is one of the great challenges for FPV systems, as it is for solar panel manufacturers. Scotra has built an FPV system on salt water in Korea and has been monitoring it for the past five years to ascertain environmental effects and the impact of tides and salinity. Based on the confidence obtained from this experience, Scotra has organized a research consortium of 15 institutions and is leading a government research project on FPV systems in the sea environment.

**FIGURE 6.6. Scotra's FPV installations in Korea** (left is Korea's largest FPV system)



Source: © Scotra.



Source: © Scotra.



### 6.2.6. Sumitomo Mitsui Construction (SMCC)

Sumitomo Mitsui Construction Co., Ltd. (SMCC) is a large Japanese general construction company. Since 2015, SMCC has ventured into supplying float systems for FPV installations. It sells floats under the brand name “PuKaTTo” that have been deployed on various types of water bodies such as lakes, water reservoirs, industrial water retaining ponds and flood control reservoirs (figure 6.7).

SMCC manufactures floats with a proprietary design that is slightly different from other mainstream suppliers. Like for other suppliers, floats are made from sturdy, UV-resistant HDPE, but its uniqueness lies in the fact that the floats are filled with polystyrene foam. Consequently, floats will not sink even when damaged. SMCC further claims that these floats are three to five times more rigid than hollow products, thereby minimizing the risk of plastic expansion. Another specificity of SMCC float system is the use of flexible binding bands to connect the floats, allowing the floats to move along with the waves, thereby minimizing impact on the fixing parts and the modules. Also, to enhance cooling from water, central part of the floats contains a large aperture.

SMCC can also provide mooring design services building on the group’s experience in offshore wind. SMCC also has its own wind tunnel testing facility.

In August 2018, SMCC announced the development of a new float supporting 72-cell solar panels (instead of 60-cell panels).<sup>29</sup> At present, one solar panel is mounted on each float at a tilt of 10°. As with other suppliers’ systems, float assembly is simple and quick. Moreover, the compact and regular shape of floats increases packing density and reduces transportation costs.

### 6.2.7. Sungrow

Established in 2016, Huainan Sungrow Floating Module Scientific and Technical Co., Ltd (Sungrow Floating) is a subsidiary of Sungrow Group, which has 21 years of solar power research and production experience, predominantly in the area of PV inverters. The company has been devoting research and development on FPV systems for the past three years. More than 30 patents cover aspects of the HDPE pure-float, matrix-type floating platforms supplied by the company.

Sungrow Floating has supplied many projects in China (figure 6.8), including very large “Top Runner” program projects in coal-subsidence areas at the 100+ MW scale, and smaller projects in lakes, agricultural ponds, and water-treatment reservoirs. The company has also installed test systems in extremely cold and typhoon-affected regions. In addition, Sungrow is taking the lead to establish floating technology standards in China.

29. [https://tech.nikkeibp.co.jp/dm/atclen/news\\_en/15mk/081902303/?ST=msbe](https://tech.nikkeibp.co.jp/dm/atclen/news_en/15mk/081902303/?ST=msbe)

**FIGURE 6.7. Examples of SMCC’s FPV systems in Japan**



Source: © SMCC.



Source: © SMCC.



**FIGURE 6.8. Examples of Sungrow's projects in China**



Source: © Sungrow.



Source: © Sungrow.

Sungrow's floating structure consists in pure HDPE float matrix where floats can accommodate both aluminum frame panels and glass-glass panels in various layouts. Panels can be tilted at 5° or 12°. The maximum buoyancy of the floating matrix is 200 kg/m<sup>2</sup>. Inner stress is effectively neutralized through the flexible ear connection of the floating matrix. The stability of the system is significantly enhanced by Sungrow's anchoring solutions, which are based on experience with ocean engineering.

The HDPE material has passed more than 20 tests (including photoxy-aging and environmental stress crack resistance). Float products have passed more than 10 tests (e.g., of watertightness and wind resistance) and earned certification from TÜV SÜD (water quality detection, damp-heat aging, oxidation induction time, impact brittle temperature, strain relief test of opposite side angle, UV-irradiation aging, bend fatigue test, restriction of hazardous substances, environmental stress crack resistance). All materials are food-grade and meet environmental protection standards for drinking water.

Efficient cooling can be achieved using the flat surface of the main floating body and aluminum brackets. This combination not only ensures proper panel tilt, but also maintains enough space between the panels and the main floating body to facilitate ventilation and heat dissipation.

Sungrow can also provide additional services such as designing the anchoring system and turnkey EPC design and construction via its parent company, Sungrow Power Supply Co., Ltd. In general, Sungrow Floating warranties its products for five years, extendable depending on contracts.

### **6.2.8. Xiamen Mibet New Energy**

Xiamen Mibet New Energy Co., Ltd (Mibet Energy) specializes in researching, developing, manufacturing, and selling PV-related products, mainly mounting structures and trackers. With its independent intellectual property, Mibet Energy offers first-class mounting solutions around the world. Its ground-based, roof-based, and floating MRac PV mounting systems, as well as its MRac tracker mounting system, are sold in more than 100 countries. They have received international certifications such as AS/NZS1170, TÜV SÜD, MCS, UL, and SGS.

G4S is the latest version of the MRac FPV mounting system. Its HDPE floats have passed the Hunt Water Absorption Test, Anti-Aging Test, and Anti-UV Test, among others. Mibet Energy claims a product lifetime of more than 25 years, increased volume of floats to improve buoyancy (which can reach 150 kg/m<sup>2</sup>), modularity with various array designs that are easily combined to form complex islands and product durability established by extensive tests and certifications such as (i) aging test by TÜV SÜD, (ii) wind-load resistance

**FIGURE 6.9. Examples of Mibet Energy's projects in China**



Source: © Mibet Energy.



Source: © Mibet Energy.

tested by TÜV SÜD, and (iii) quality-of-water test by NSF (United Kingdom), ensuring environmental friendliness and compatibility with drinking water. Examples of the company's projects are shown in figure 6.9.

### 6.3. Providers of floating technology solutions for offshore or near-shore applications

This section describes in alphabetical order two suppliers of FPV technology for offshore or near-shore applications. Because these applications are still limited to date, suppliers in this segment have not reached the threshold of 5 MWp of installed capacity. However, this could change in the near future.

#### 6.3.1. Ocean Sun

Ocean Sun was founded in 2016 to develop and commercialize a novel floating solar concept based on the installation of PV modules onto a large, free-floating, hydroelastic membrane. The method differs fundamentally from existing FPV systems since the modules are cooled by direct contact with the hydroelastic membrane as opposed to conventional air-cooling. The operating temperature of PV cells is held close to the water temperature, enabling the system to produce

significantly more energy than regular FPV systems under good insolation. By minimizing the materials needed, the design also reduces costs and logistics challenges.

The hydroelastic membrane is attached to an outer perimeter of moored buoys so that the floater is not dragged under the mooring, even in strong currents. Elements of the mooring technique are derived from industrial fish farming in rough waters in Norway. Accumulated rainwater is diverted over the freeboard using bilge pumps. The circular geometry is beneficial with respect to external forces under harsh conditions. A rectangular shape can be used in more benign waters or inland reservoirs.

Thanks to the hydroelastic properties and dampening effect of the membrane, the system can cope with relatively large waves. Watertight, it offers a protective barrier against saltwater. In 1.5 years of marine testing, the system has performed well. The concept has also been modelled to scale in basin laboratory and behaves well in waves up to three meters ( $H_s^{29} < 1.5$  m). If necessary, the torus rim and freeboard can be optimized further to cope with the slamming force of higher waves.

30.  $H_s$ =significant wave height, defined as the mean wave height (trough to crest) of the highest third of the waves.

The membrane is made of a strong, polymer-coated textile, dimensioned to withstand the tensile forces exerted by waves, current, and wind. The buoyant double torus is constructed from HDPE piping. All the floater materials are approved for drinking water and are carefully selected with respect to UV and hydrolysis resistance. Mathematical modelling using both analytical and the finite element method, as well as instrumented tests in a basin laboratory, shows that the PV modules are subjected to low stress and deflections. For modules with adequate stiffness (such as the typical 60-cell glass-glass module), mechanical stress is significantly lower than the stress occurring in the wind-load test with four-point clamping described in the IEC61215 standard. Modules also have more stable thermal contact with the water body, and the thermally induced stresses acting on the metallic conductors from temperature fluctuations between day and night is eliminated. Because the modules are horizontal, the system performs best in the lower latitudes; the sleek design offers excellent wind resistance. Construction has been modelled with good results using computational fluid dynamics for wind speeds up to 275 km/h. This velocity is equivalent to typhoon category 4.

Ocean Sun offers design specifications, EPC for 1 MW demonstration installations, consultancy, and follow-up. The unconventional floater design is still subject to development and qualification and is not yet direct-

ly bankable. Early adopters are strong independent power producers interested in a new, low-cost floater technology with high yield, able to carry risk, and possessing the engineering resources to do in house assessments. Certification work has been initiated with a major third-party classification company.

Ocean Sun operates two smaller test systems in Norway and in Singapore. A third 100 kWp off-grid system supplies power to a large fish farm on the western coast of Norway (figure 6.10). Ocean Sun is currently building 2.2 MWp on two hydroelectric power dams in Southeast Asia and South Europe, respectively.

### 6.3.2. Swimsol

Swimsol was founded in 2012 and has become the major solar PV company in the Maldives, with an installed capacity of 2.5 MW (rooftop PV) through end 2018.

Swimsol's first pilot SolarSea system was implemented in 2014 (figure 6.11). By 2018, eight platforms with a total capacity of 200 kWp had been installed at three different locations (two island resorts, one local island). By the second quarter of 2019 another 2 MWp rooftop and 400 kWp FPV system will be installed.

Swimsol's SolarSea solution has been developed and continuously optimized over more than eight years.

**FIGURE 6.10. Offshore floaters in Norway, 50 meters in diameter (left) and 20 meters in diameter (right)**



Source: © Ocean Sun.



Source: © Ocean Sun.

**FIGURE 6.11. Swimsol's FPV systems in the Maldives**



Source: © Swimsol.

The system has proven since 2014 to withstand waves, wind, and harsh conditions at sea, and is built to last 30 years. It is designed in such a way as to be easily assembled on site (i.e., on a beach) and is commercially competitive with diesel generators.

Swimsol systems are designed and dimensioned to suit specific requirements. To this end, Swimsol provides related services such as site selection and preparation and analysis of the existing electrical grid. Typically, FPV system components are preassembled at Swimsol's plant in Austria. Swimsol installs the systems on site, including mooring and anchoring, to ensure the quality of the entire system. The company also applies hybrid solutions to integrate the solar power generated by its systems into the existing power grid. This is particularly beneficial for users of diesel generators, who are able to reduce fuel costs by not running certain generators during sunshine hours. Swimsol systems include equipment that monitors the system via live Internet feed. On request, Swimsol can also propose financing for floating projects.

Swimsol's SolarSea product is the result of five years of modelling, computer simulations, and testing in



Source: © Swimsol.

wave tanks and under actual conditions. Its low-volume, truss-like floating structure, with a patented float distribution, creates an elevated surface area that isolates solar panels from the effects of waves. Several versions of SolarSea are available for different wave conditions and can produce electricity at costs as low as US\$0.12 per kWh.

Working with electronics in a tropical marine environment is always a challenge. For each installation, Swimsol selects the most appropriate stress-tested components of the highest quality, including heavy-duty, high-performance panels developed specifically for tropical marine environments. Systems have a lifetime of around 30 years.

SolarSea's effects on marine flora and fauna have been found by Swimsol to be negligible. Platforms are installed only above sandy sea beds and coral patches are strictly avoided. A detailed environmental study of Swimsol's longest-serving floating systems has shown significant positive effects, such as new coral growth, whereby the platforms have become a habitat for fish and crustaceans.





Funding gratefully  
acknowledged from

